

RoHS  Lead-free

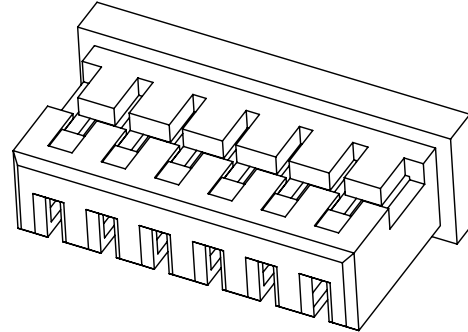
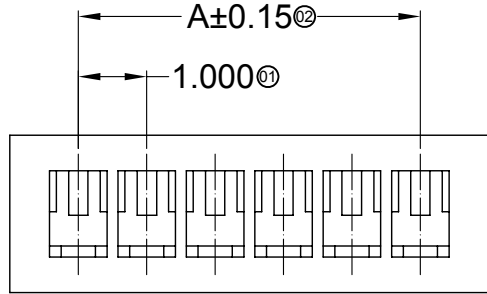

■ Specifications :

- Voltage rating: 125V AC / DC
- Current rating: 1A AC / DC
- Withstanding voltage: 500V AC/minute
- Temperature range: -25°C~+85°C
- Insulation resistance: ≥100MΩ
- Contact resistance: ≤20mΩ
- After environmental testing: ≤30mΩ

1003 H X-XX X-N0 HF
① ② ③ ④ ⑤ ⑥ ⑦

- ① Series No.
- ② Category: H-HSG
- ③ Appearance type: Blank-Ordinary
- ④ Row No.-Pin No.: XX-02P~20P
- ⑤ Plug the Pin & Special No.:
- ⑥ Material : N0-PA66 UL 94V-0
- ⑦ Color : HF-Halogen free

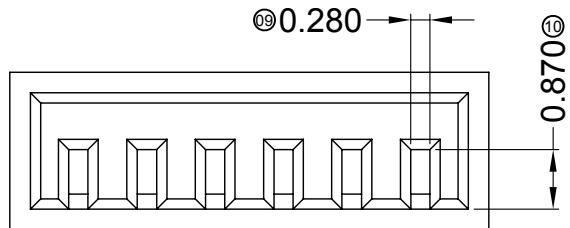
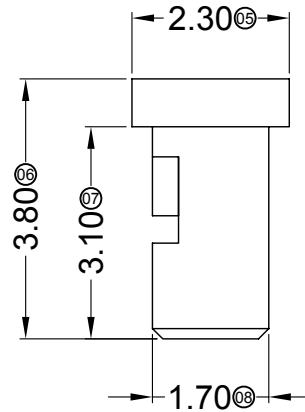
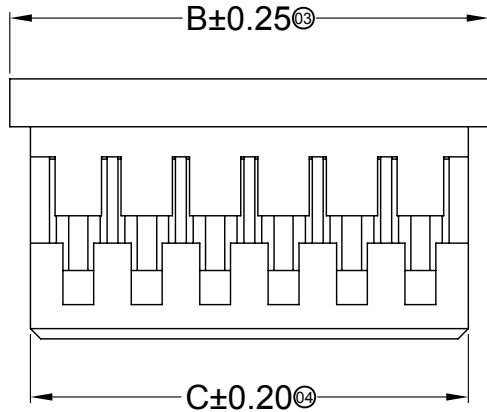

Poles	Dimensions (mm)			Poles	Dimensions (mm)		
	A	B	C		A	B	C
02	1.00	3.00	2.40	12	11.00	13.00	12.40
03	2.00	4.00	3.40	13	12.00	14.00	13.40
04	3.00	5.00	4.40	14	13.00	15.00	14.40
05	4.00	6.00	5.40	15	14.00	16.00	15.40
06	5.00	7.00	6.40	16	15.00	17.00	16.40
07	6.00	8.00	7.40	17	16.00	18.00	17.40
08	7.00	9.00	8.40	18	17.00	19.00	18.40
09	8.00	10.00	9.40	19	18.00	20.00	19.40
10	9.00	11.00	10.40	20	19.00	21.00	20.40
11	10.00	12.00	11.40				

1003H-XX-N0HF	PA 66 UL 94V-0 Halogen Free	1003T	1003W
PART NO	Material	Suitable SWB Terminal	Mates With SWB Wafer

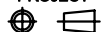
						GENERAL TOLERANCE		 思索连接器有限公司 SWB CONNECTORS CO.,LTD				PART NO. 1003H-XX-N0HF				
2014/09/18	B	C	/	Space of a Whole page Changes	Wuxiaotao	Jova	.X					±0.30	TITLE 1.00mm Crimp Style Connectors			
2013/08/07	A	B	/	Modify the drawing frame format			.XX	±0.20	APPROVAL	CHECK	DRAWN	DATA				
DATE	OLD REV	NEW REV	ECN	DESCRIPTION	CHECK	APPROVAL	PROJECT	±0.10		孙开宝	黄明娟	2012/12/21	UNIT	SCALE	NUMBER	REV
													MM	1:1	A-106	C

RoHS  Lead-free

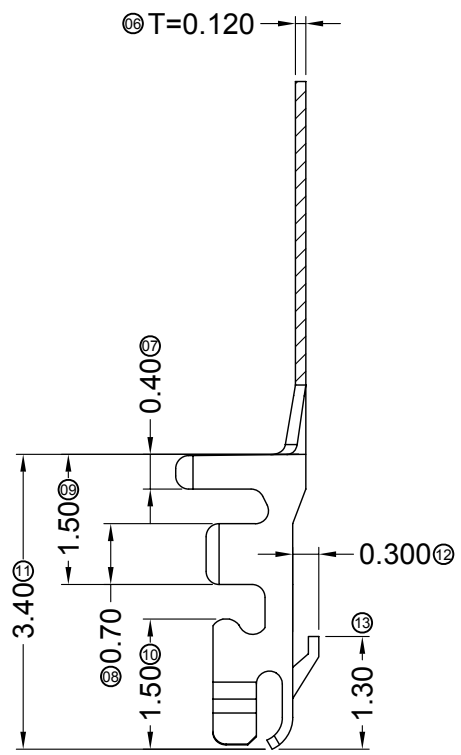
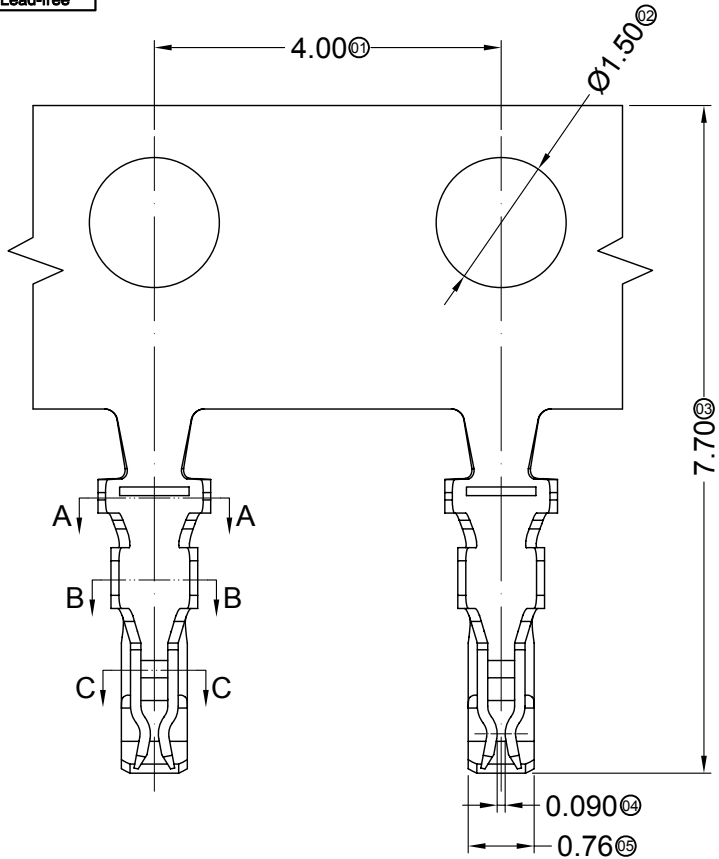

- Specifications :**
- Voltage rating: 125V AC / DC
 - Current rating: 1A AC / DC
 - Withstanding voltage: 500V AC/minute
 - Temperature range: -25°C~+85°C
 - Insulation resistance: ≥100MΩ
 - Contact resistance: ≤20mΩ
 - After environmental testing: ≤30mΩ

1003 T X-P SN X
 ① ② ③ ④ ⑤ ⑥

- ① Series Number
- ② Category: T-terminal
- ③ Shape: Blank-ordinary
- ④ Material: P-Phosphor bronze
- ⑤ Plating style: SN-Bright tin plating
- ⑥ Plating method: Blank-Stamping before plating

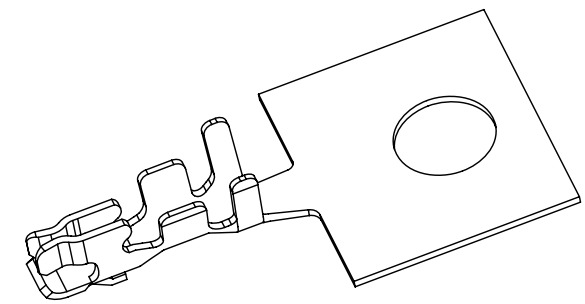
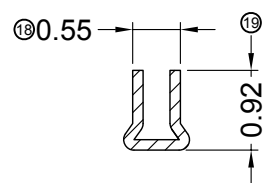
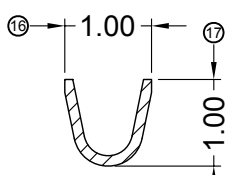
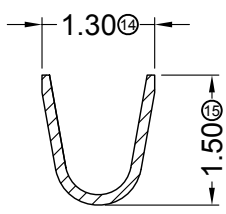

1003T-PV01	Phosphor Bronze	AWG#28-32	0.92mm	Stamping Before Plating:30u" MIN. Ni; Whole Gold :Gold Flash	1003H
1003T-PSN				Stamping Before Plating:30u" MIN. Ni; 70u" MIN.Sn	
PART NO	Material	Wire Range	Insulation O.D.	Finish	Used In SWB Housing

2014/09/17	A	B		Modify the drawing frame format	Wuxiaotao	Jova	
DATE	OLD REV	NEW REV	ECN	DESCRIPTION	CHECK	APPROVAL	PROJECT

GENERAL TOLERANCE	
.X	±0.30
.XX	±0.20
.XXX	±0.10

SWB 思索连接器有限公司
 TERMINAL&CONNECTORS SWB CONNECTORS CO.,LTD

APPROVAL	CHECK	DRAWN	DATA
		Luna	2012/12/21

PART NO. 1003T-PXXX			
TITLE 1.00mm Crimp Style Connectors			
UNIT MM	SCALE 1:1	NUMBER A-106	REV B