

■ Specifications :

- Voltage rating: 125V AC / DC
- Current rating: 1A AC / DC
- Withstanding voltage: 250V AC/minute
- Temperature range: -25°C~+85°C
- Insulation resistance: ≥100MΩ
- Contact resistance: ≤30mΩ
- After environmental testing: ≤40mΩ

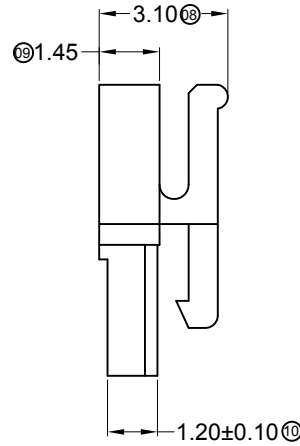
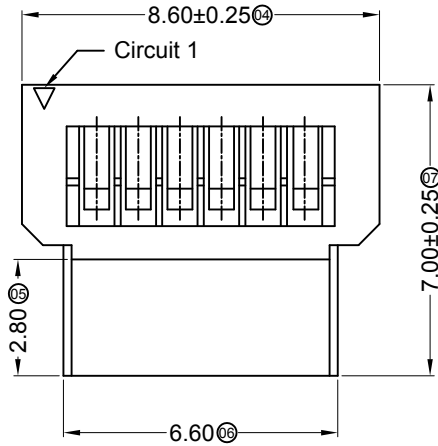

1013 H X - 06 X-46 XX

- (1) Series No.
 (2) Category: H-HSG
 (3) Welding Board Angle: Blank-ordinary
 (4) Row No.-Pin No.: XX-Single row
 (5) Plug the Pin & special No.
 (6) Material: 46-PA46 94V-0
 (7) Color: Blank-natural color

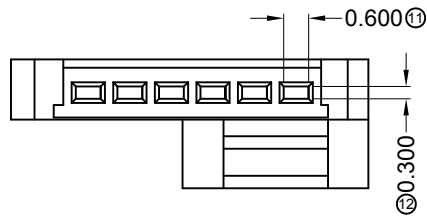

1013H-06-46	Nylon 46 UL 94V-0	1013T	1013W
PART NO	Material	Suitable SWB Terminal	Suitable SWB Wafer

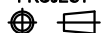
				GENERAL TOLERANCE				PART NO. 1013H-06-46							
2013/08/15	B	C		Modify the drawing frame format			 思索连接器有限公司 SWB CONNECTORS CO.,LTD	TITLE 1.00mm Crimp Style Connectors							
2011/09/08	A	B		Modify the drawing frame format				APPROVAL	CHECK	DRAWN	DATA				
DATE	OLD REV	NEW REV	ECN	DESCRIPTION	CHECK	APPROVAL	PROJECT	Bob Sun	Jova Lau	yan.Liu	2007/05/03	UNIT	SCALE	NUMBER	REV
												MM	1:1	A-033	C

RoHS  Lead-free

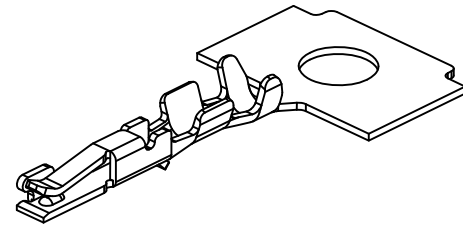
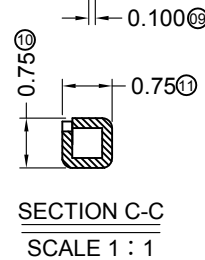
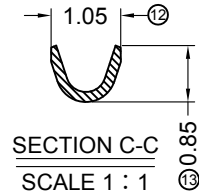
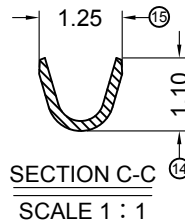
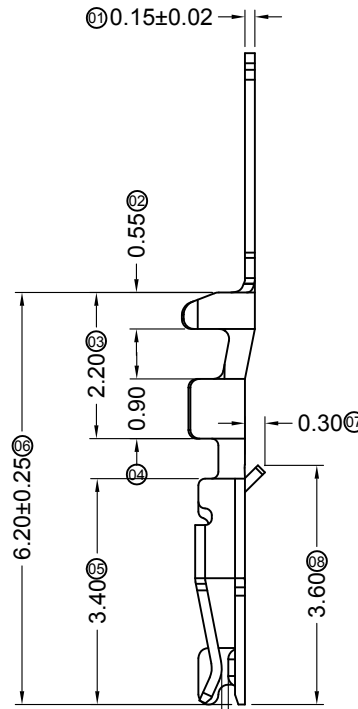
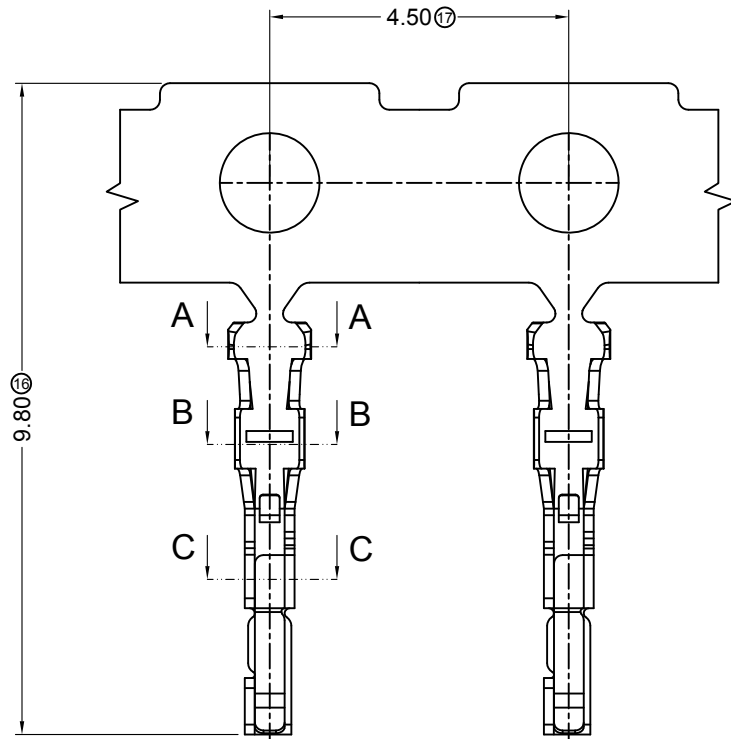

- Specifications :
- Voltage rating: 125V AC / DC
 - Current rating: 1A AC / DC
 - Withstanding voltage: 250V AC/minute
 - Temperature range: -25°C~+85°C
 - Insulation resistance: ≥100MΩ
 - Contact resistance: ≤30mΩ
 - After environmental testing: ≤40mΩ

1013 T X-P V01 X-X
① ② ③ ④ ⑤ ⑥ ⑦

- ① Series No
- ② Category: T-Terminal
- ③ Welding Way: Blank-Normal Leads
- ④ Material: P-Phosphor bronze
- ⑤ Plating Category: V01- All Gold-Flash
- ⑥ Plating Way: Blank-stamping before plating
- ⑦ Mold No/MARK&Special No

PART NO	Wire Range	Insulation O.D	Material	Stamping Before Pating:30u" Ni; Whole Gold :Gold Flash	1013H
1013T-PV01	AWG#28~32	0.80mm Max.	Phosphor Bronze	Finish	Used In SWB Housing

							GENERAL TOLERANCE .X ±0.30 .XX ±0.20 .XXX ±0.10				 思索连接器有限公司 SWB CONNECTORS CO.,LTD				PART NO. 1013T-PV01 TITLE 1.00mm Crimp Style Connectors			
2014/07/27	B	C	Add Wire Range				svlyia	APPROVAL				DATA						
2014/02/17	A	B	Modify the drawing frame format				svlyia	Jova				2007/05/03						
DATE	OLD REV	NEW REV	ECN	DESCRIPTION	CHECK	APPROVAL	PROJECT	W.X.T	yan.Liu	2007/05/03	UNIT MM	SCALE 1:1	NUMBER A-106	REV C				