

RoHS  Lead-free

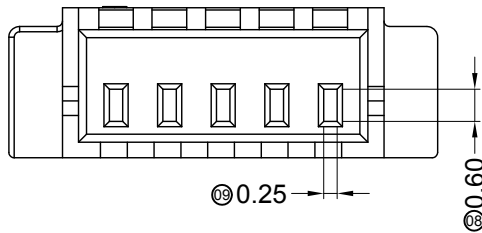
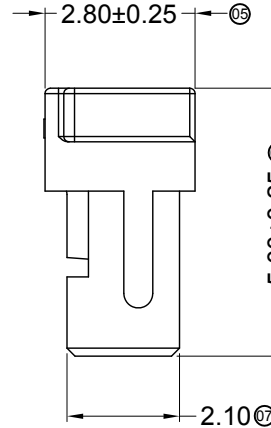
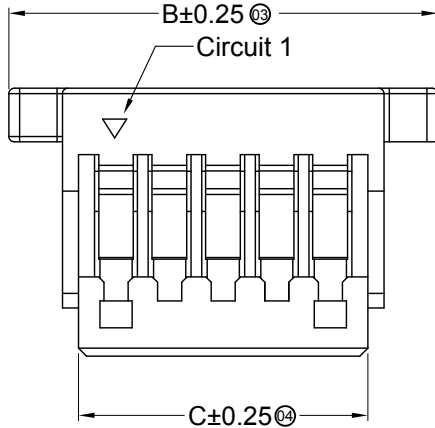
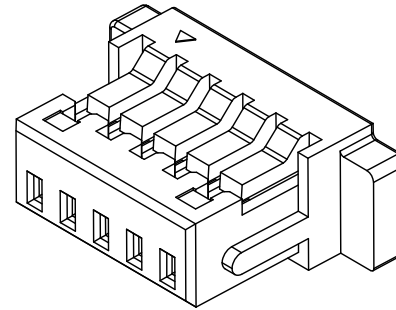
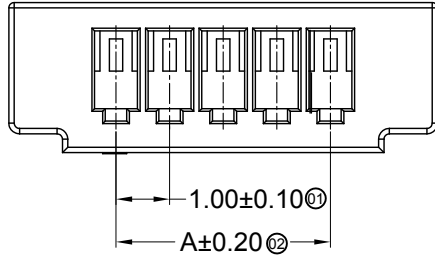

■ Specifications :

- Voltage rating: 50V AC / DC
- Current rating: 1A AC / DC
- Withstanding voltage: 500V AC/minute
- Temperature range: -25°C~+85°C
- Insulation resistance: ≥100MΩ
- Contact resistance: ≤20mΩ
- After environmental testing: ≤40mΩ

1002 H X-XX E-XX XX XX

① ② ③ ④ ⑤ ⑥ ⑦ ⑧

- ① Series No.
- ② Category: H-HSG
- ③ Welding Board Angle: Blank-ordinary
- ④ Row No.-Pin No.: XX-02P~24P
- ⑤ Plug the Pin & special No.: E-Have ears
- ⑥ Material: PT-PBT ; N0-PA66 94V-0
PGN0-P-640PG3G-NC(15%GF)
- ⑦ Color: Blank-natural color
- ⑧ HF- Halogen Free ; Blank- Halogen

Poles	Dimensions(mm)			Poles	Dimensions(mm)		
	A	B	C		A	B	C
02	1.00	5.00	2.40	13	12.00	16.00	13.40
03	2.00	6.00	3.40	14	13.00	17.00	14.40
04	3.00	7.00	4.40	15	14.00	18.00	15.40
05	4.00	8.00	5.40	16	15.00	19.00	16.40
06	5.00	9.00	6.40	17	16.00	20.00	17.40
07	6.00	10.00	7.40	18	17.00	21.00	18.40
08	7.00	11.00	8.40	19	18.00	22.00	19.40
09	8.00	12.00	9.40	20	19.00	23.00	20.40
10	9.00	13.00	10.40	22	21.00	25.00	22.40
11	10.00	14.00	11.40	24	23.00	27.00	24.40
12	11.00	15.00	12.40				

1002H-XXE-PGN0HF	PA66 UL 94V-0 Halogen Free P-640PG3G-NC(15%GF)	1002T	1002W
1002H-XXE-N0HF	PA66 UL 94V-0 Halogen Free		
1002H-XXE-N0	PA66 UL 94V-0		
1002H-XXE-PT	PBT UL 94V-0		
PART NO	Material	Suitable SWB Terminal	Mates With SWB Wafer

DATE	OLD REV	NEW REV	ECN	DESCRIPTION	CHECK	APPROVAL	PROJECT	APPROVAL	CHECK	DRAWN	DATA	UNIT	SCALE	NUMBER	REV	
2014/03/06	B	C		Space of a Whole page Changes	Sylvia		GENERAL TOLERANCE					MM	1:1	A-022	B	
2014/02/07	A	B		Space of a Whole page Changes	Sylvia		.X ±0.30									
							.XX ±0.20									
							.XXX ±0.10									

SWB 思索连接器有限公司
SWB CONNECTORS CO.,LTD

PART NO. 1002H-XXE-XXHF

TITLE 1.00 mm Crimp Style Commcttors

APPROVAL Bob Sun
CHECK Jova Lau
DRAWN Allen
DATA 2013/08/31

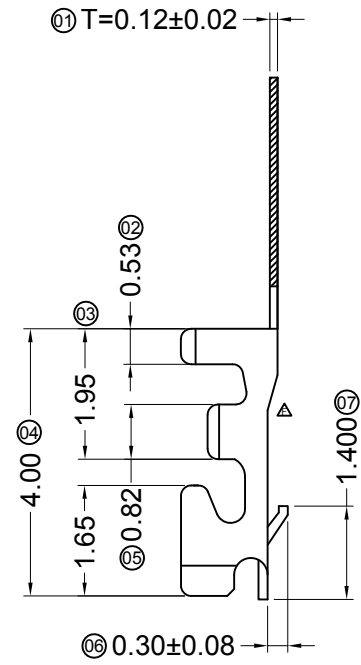
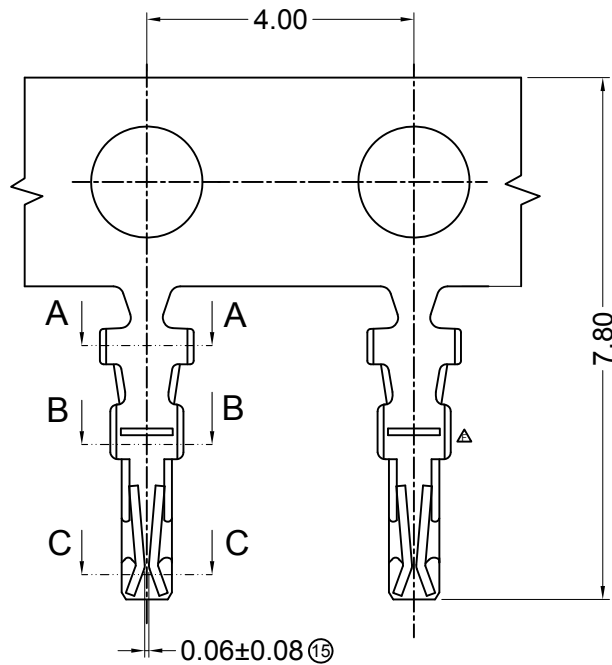

■ Specifications :

- Voltage rating: 50V AC / DC
- Current rating: 1A AC / DC
- Withstanding voltage: 500V AC/minute
- Temperature range: -25°C~+85°C
- Insulation resistance: ≥100MΩ
- Contact resistance: ≤20mΩ
- After environmental testing: ≤40mΩ

1002 T X-P XX X-X

- ① Series Number
- ② Category: T-terminal
- ③ Shape: Blank-ordinary
- ④ Material: P-Phosphor bronze
- ⑤ Plating style:
V**-All Gold-Plated ; *01-Gold Flash ; *03-3u"
SN-Bright tin plating 70-120u"
SN2-Bright tin plating 120u"Min. Ni : 50u" Min.
- ⑥ Plating method:
Blank-Stamping before plating
B-Plating before stamping
- ⑦ Mold No./Mark/Special No.

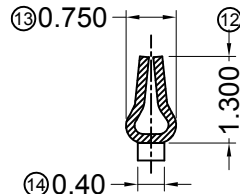

SECTION C-C
SCALE 1:1

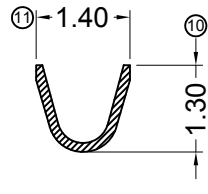

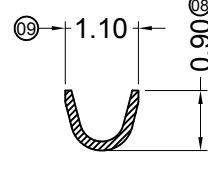

SECTION A-A
SCALE 1:1



SECTION B-B
SCALE 1:1

1002T-PV03				Stamping Before Pating:30-50u" Ni;Whole Gold :3u" Min.	
1002T-PV01	Phosphor Bronze	AWG#28-32	0.80mm(Max)	Stamping Before Pating:30-50u" Ni;Whole Gold :Gold Flash	1002H
1002T-PSN2				Stamping Before Pating:50u" Min Ni;120u"Sn Min	
1002T-PSN				Stamping Before Pating:30-50u" Ni;70~120u"Sn	
PART NO				Material	

2014/08/02	E	F		Add Pull lines Break bad	sylvania		GENERAL TOLERANCE .X ±0.30 .XX ±0.20 .XXX ±0.10 PROJECT 	 思索连接器有限公司 SWB CONNECTORS CO.,LTD	PART NO. 1002T-PXX					
2014/01/22	D	E	Space of a Whole page Changes	sylvania		TITLE 1.00 mm Crimp Style Connectors								
2013/08/31	C	D	Modify drawing frame format	Allen		APPROVAL			CHECK	DRAWN	DATA			
DATE	OLD REV	NEW REV	ECN	DESCRIPTION	CHECK	APPROVAL			Bob Sun	Jova Lau	Allen	2013/08/31	UNIT MM	SCALE 1:1

RoHS  Lead-free

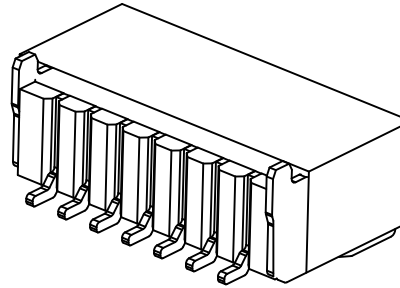
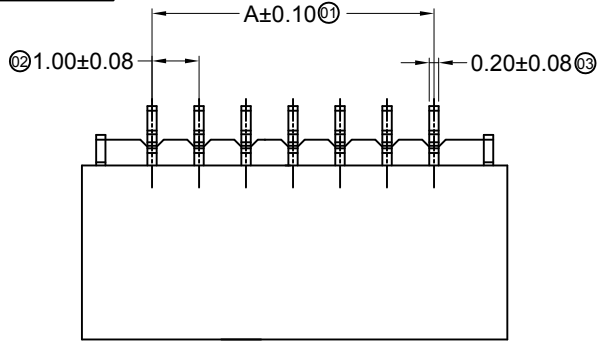

Specifications :

- Voltage rating: 50V AC / DC
- Current rating: 1A AC / DC
- Withstanding voltage: 500V AC/minute
- Temperature range: -25°C~+85°C
- Insulation resistance: ≥100MΩ
- Contact resistance: ≤20mΩ
- After environmental testing: ≤40mΩ

1002 W R S-XX E-LP XX XX XX
 ① ② ③ ④ ⑤ ⑥ ⑦ ⑧ ⑨ ⑩

- ① Series No.
- ② Category: W-wafer
- ③ Welding Board Angle: R-90°
- ④ Welding Way: S-SMT
- ⑤ Row No.-Pin No.: XX-02P~20P
- ⑥ Plug the Pin & Special No.: E-Ear clip
- ⑦ Material: LP-LCP 94V-0
- ⑧ Planting Category:
 V** : All Gold-Plated *01-Gold Flash
 SW-Fog Tin plating
- ⑨ Color: Blank-natural color
- ⑩ HF-Halogen Free ; Blank- Halogen

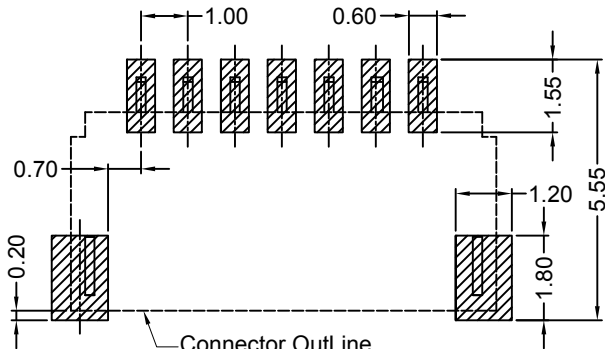
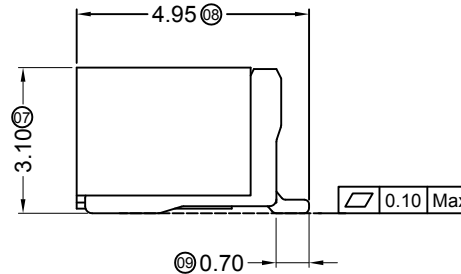
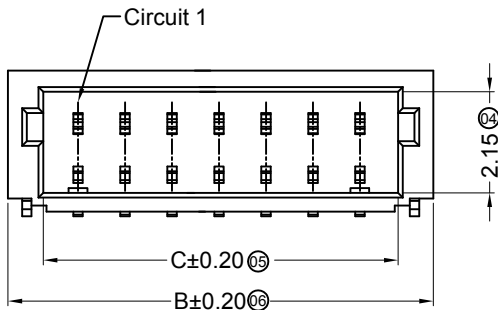

Connector Outline
 Recommended P.C.B Layout
 General Tolerance ±0.05

Poles	Dimensions(mm)			Poles	Dimensions(mm)		
	A	B	C		A	B	C
02	1.00	4.00	2.50	10	9.00	12.00	10.50
03	2.00	5.00	3.50	11	10.00	13.00	11.50
04	3.00	6.00	4.50	12	11.00	14.00	12.50
05	4.00	7.00	5.50	13	12.00	15.00	13.50
06	5.00	8.00	6.50	14	13.00	16.00	14.50
07	6.00	9.00	7.50	15	14.00	17.00	15.50
08	7.00	10.00	8.50	16	15.00	18.00	16.50
09	8.00	11.00	9.50	20	19.00	22.00	20.50

PART NO	Material	Material(Pin And Solder Tabs)	Finish(Pin And Solder Tabs)	Mates With SWB Housing
1002WRS-XXE-LPV01	LCP UL 94V-0	Phosphor Bronze	Gold Flash	1002H
1002WRS-XXE-LPSWHF	LCP UL 94V-0 Halogen Free		Tin Plating Fog	
1002WRS-XXE-LPSW	LCP UL 94V-0			

DATE	OLD REV	NEW REV	ECN	DESCRIPTION	CHECK	APPROVAL	PROJECT	APPROVAL	CHECK	DRAWN	DATA	UNIT	SCALE	NUMBER	REV
2014/02/24	B	C		Add Gold Plated Part No	Jova		GENERAL TOLERANCE .X ±0.30 .XX ±0.20 .XXX ±0.10	SWB TERMINAL&CONNECTORS	思索连接器有限公司 SWB CONNECTORS CO.,LTD	PART NO. 1002WRS-XXE-LPXXXX					
2014/02/10	A	B		Space of a Whole page Changes	Sylvia					TITLE 1.00 mm Crimp Style Connectors					
								Bob Sun	Jova Lau	Allen	2013/08/31	MM	1 : 1	A-084	C

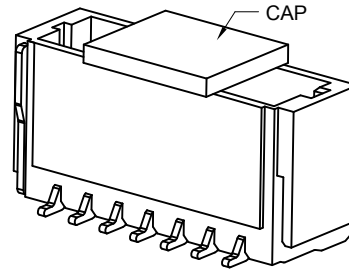
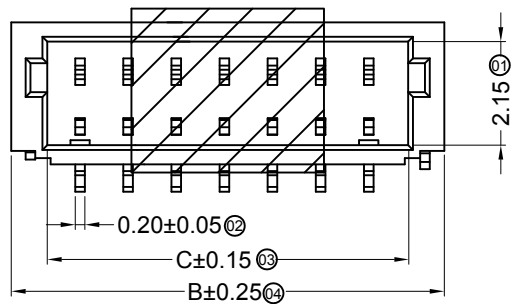

Specifications :

- Voltage rating: 50V AC / DC
- Current rating: 1A AC / DC
- Withstanding voltage: 500V AC/minute
- Temperature range: -25°C~+85°C
- Insulation resistance: ≥100MΩ
- Contact resistance: ≤20mΩ
- After environmental testing: ≤40mΩ

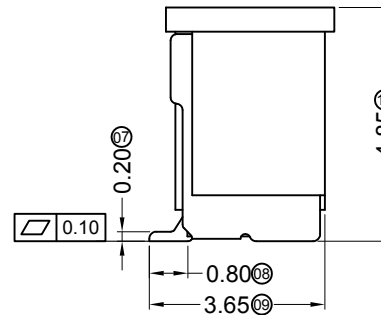
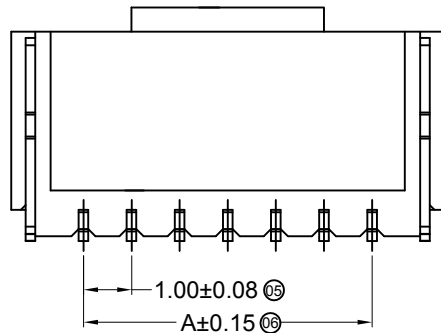

1002 W V S-XX E-LP SW XX XX

① ② ③ ④ ⑤ ⑥ ⑦ ⑧ ⑨ ⑩

- ① Series No.
- ② Category: W-wafer
- ③ Welding Board Angle: V-180°
- ④ Welding Way: S-SMT
- ⑤ Row No.-Pin No.: XX-02P~20P
- ⑥ Plug the Pin & Special NO.: E-Ear clip
- ⑦ Material: LP-LCP 94V-0
- ⑧ Planting Category: SW-Matte Tin plating (Tin: 70u Min)
- ⑨ Color: Blank-Natural color
- ⑩ HF-Halogen Free ; Blank-Halogen

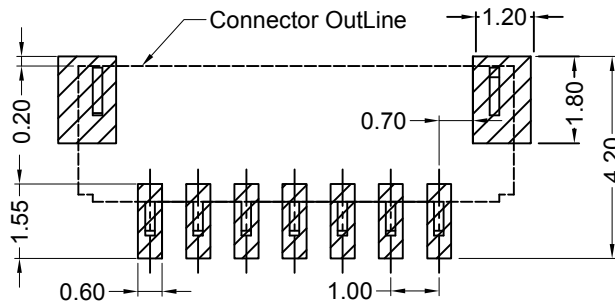

Recommended P.C.B Layout
General Tolerance±0.05

Poles	Dimensions(mm)			Poles	Dimensions(mm)		
	A	B	C		A	B	C
02	1.00	4.00	2.50	10	9.00	12.00	10.50
03	2.00	5.00	3.50	11	10.00	13.00	11.50
04	3.00	6.00	4.50	12	11.00	14.00	12.50
05	4.00	7.00	5.50	13	12.00	15.00	13.50
06	5.00	8.00	6.50	14	13.00	16.00	14.50
07	6.00	9.00	7.50	15	14.00	17.00	15.50
08	7.00	10.00	8.50	16	15.00	18.00	16.50
09	8.00	11.00	9.50	20	19.00	22.00	20.50

1002WVS-XXE-LPSWHF	LCP UL 94V-0 Halogen Free	Phosphor Bronze	Tin Plating Fog	1002H
1002WVS-XXE-LPSW	LCP UL 94V-0			
PART NO	Material	Material (Pin And Solder Tabs)	Finish (Pin And Solder Tabs)	Mates With SWB Housing

2014/02/10	A	B	Space of a Whole page Changes	Sylvia		
DATE	OLD REV	NEW REV	ECN	DESCRIPTION	CHECK	APPROVAL

GENERAL TOLERANCE
.X ±0.30
.XX ±0.20
.XXX ±0.10

SWB 思索连接器有限公司
TERMINAL&CONNECTORS SWB CONNECTORS CO.,LTD

PART NO. 1002WVS-XXE-LPSWXX

TITLE 1.00mm Crimp Style Connectors

APPROVAL	CHECK	DRAWN	DATA
Bob Sun	Jova Lau	Allen	2013/08/31

UNIT	SCALE	NUMBER	REV
MM	1:1	A-084	B

RoHS Lead-free

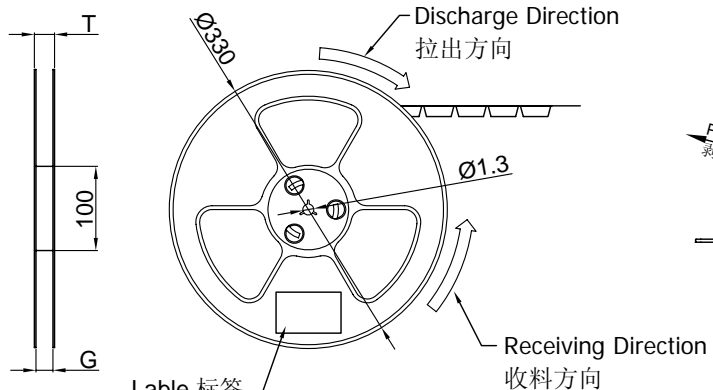
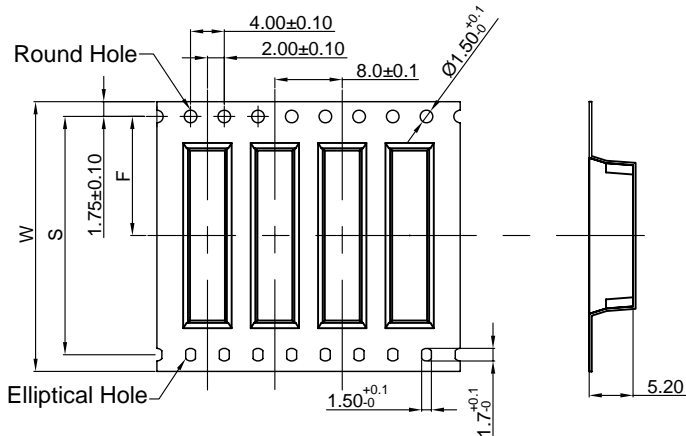
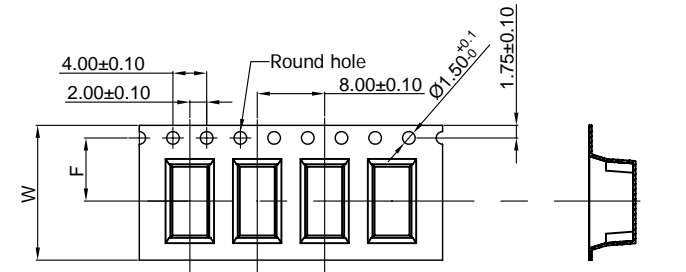
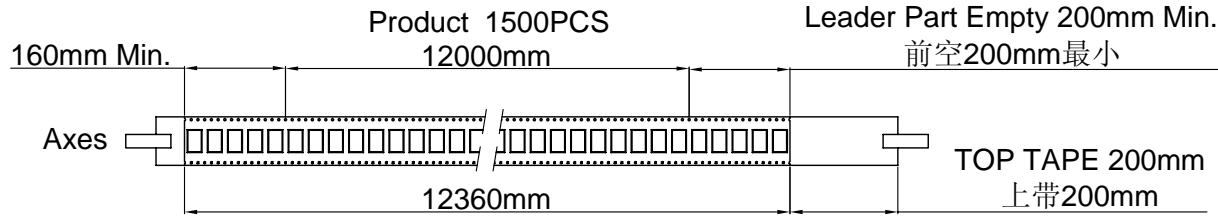

COVER TAPE PEEL STRENGTH:20~120g
上带剥离力量: 20~120g
速度 PEEL SPEED:300mm/minute

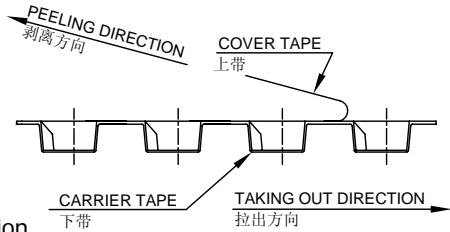

Single hole: None Hole Side
单孔: 贴无链孔侧
Double hole: Elliptical Hole Side
双孔: 贴椭圆孔侧

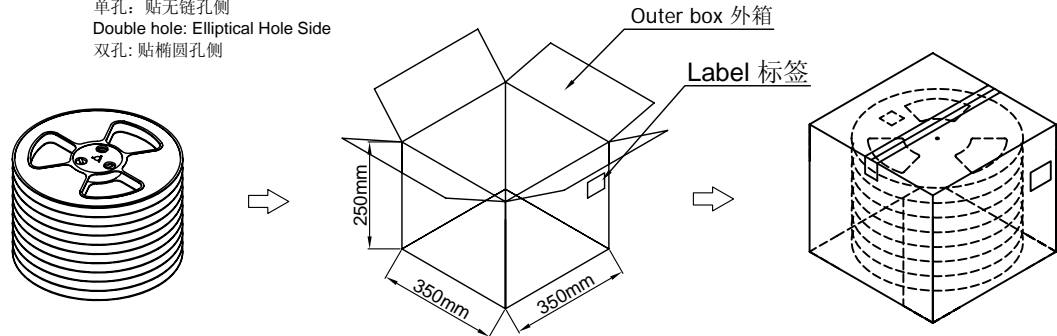

Part No.	W	S	F	T (MAX)	G (MAX)	REEL /PCS	CARTON /R	CARTON /PCS
ZD1002WVS-02E	12	/	5.50	18.50	12.50	1500	13R	19500
ZD1002WVS-03E								
ZD1002WVS-04E	16	/	7.50	20.50	16.40	1500	11R	16500
ZD1002WVS-05E								
ZD1002WVS-06E								
ZD1002WVS-07E								
ZD1002WVS-08E								
ZD1002WVS-09E								
ZD1002WVS-10E	24	/	11.50	28.50	24.40	1500	8R	12000
ZD1002WVS-11E								
ZD1002WVS-12E								
ZD1002WVS-13E								
ZD1002WVS-14E								
ZD1002WVS-15E	32	28.40	14.20	36.50	32.40	1500	6R	9000
ZD1002WVS-16E								

Note:
1. Carrier Camber Is Within 1mm In 100mm
2. 10 Sprocket Hole Pitch Cumulative Tolerance±0.2MM

							GENERAL TOLERANCE		SWB 思索连接器有限公司 TERMINAL&CONNECTORS SWB CONNECTORS CO.,LTD				PART NO. PPN: 1002WVS-XXE-XXXX CPN: ZD1002WVS-XXE			
							.X	±0.30	APPROVAL				TITLE			
							.XX	±0.20	CHECK				1.00mm Connectors SMT 180° Package			
							.XXX	±0.10	DRAWN				UNIT			
DATE	OLD REV	NEW REV	ECN	DESCRIPTION	CHECK	APPROVAL	PROJECT		Allen	2013/12/09	MM	SCALE	NUMBER	REV		
											1:1	A-106	A			

RoHS Lead-free

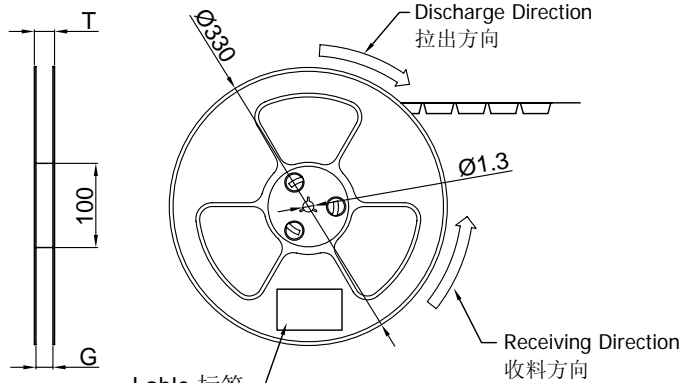
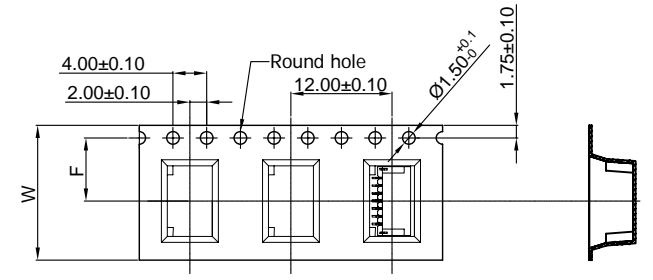
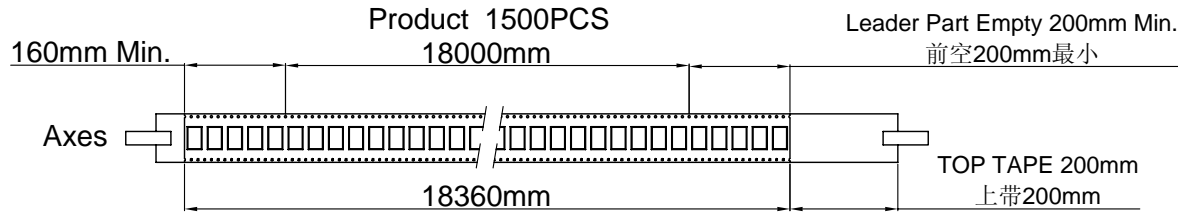

COVER TAPE PEEL STRENGTH:20~120g
上带剥离力量20~120g
速度 PEEL SPEED:300mm/minute

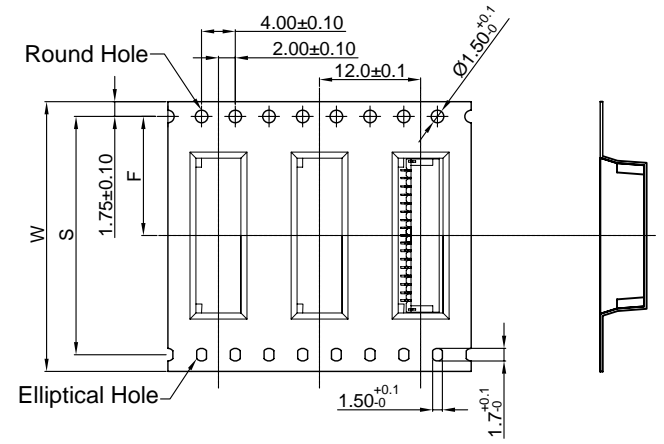
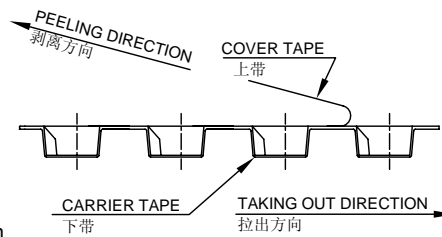

Lable 标签
Single hole: None Hole Side
单孔: 贴无链孔侧
Double hole: Elliptical Hole Side
双孔: 贴椭圆孔侧

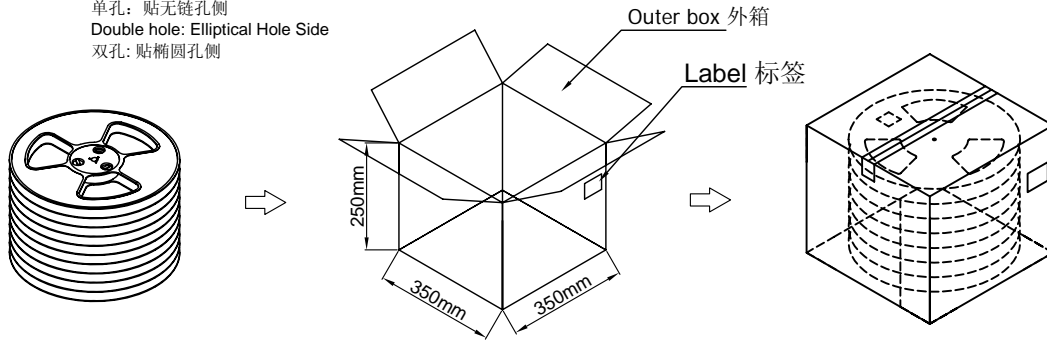

Part No.	W	S	F	T (MAX)	G (MAX)	REEL /PCS	CARTON /R	CARTON /PCS
ZD1002WRS-02E	12	/	5.50	18.50	12.50	1500	13R	19500
ZD1002WRS-03E	16	/	7.50	22.50	16.50	1500	11R	16500
ZD1002WRS-04E								
ZD1002WRS-05E								
ZD1002WRS-06E								
ZD1002WRS-07E								
ZD1002WRS-08E	24	/	11.50	30.50	24.50	1500	8R	12000
ZD1002WRS-09E								
ZD1002WRS-10E								
ZD1002WRS-11E								
ZD1002WRS-12E								
ZD1002WRS-13E	32	28.40	14.20	38.50	32.50	1500	6R	9000
ZD1002WRS-14E								
ZD1002WRS-15E								
ZD1002WRS-16E								

Note:
1. Carrier Camber Is Within 1mm In 100mm
2. 10 Sprocket Hole Pitch Cumulative Tolerance±0.2MM

GENERAL TOLERANCE
.X ±0.30
.XX ±0.20
.XXX ±0.10

SWB 思索连接器有限公司
TERMINAL & CONNECTORS SWB CONNECTORS CO.,LTD

PART NO. PPN: 1002WRS-XXE-XXXX
CPN: ZD1002WRS-XXE

APPROVAL CHECK DRAWN DATA

TITLE
1.00mm Connectors SMT 90° Package

PROJECT

UNIT SCALE NUMBER REV
MM 1:1 A-106 A

DATE OLD REV NEW REV ECN DESCRIPTION CHECK APPROVAL

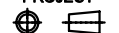

Allen 2013/12/09