

■ Specifications :

- Voltage rating: 200V AC / DC
- Current rating: 1.5A AC / DC
- Withstanding voltage: 1000V AC/minute
- Temperature range: -25°C~+130°C
- Insulation resistance: ≥1000MΩ
- Contact resistance: ≤20mΩ
- After environmental testing: ≤40mΩ

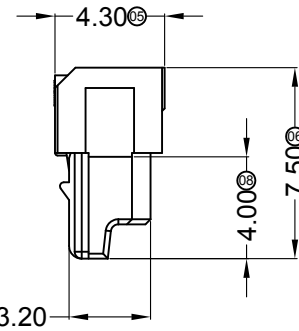
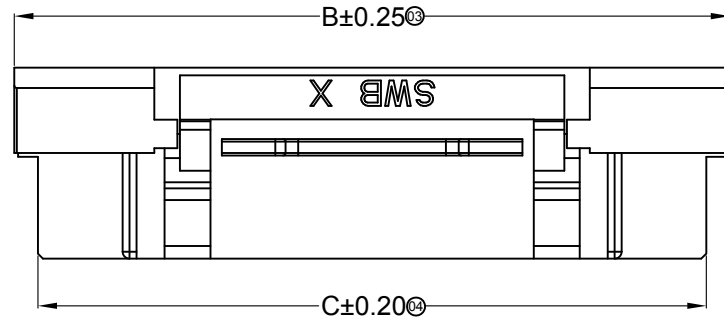

20P Shape Scale 1:1

1257 H X-XX HF-XX XX

① ② ③ ④ ⑤ ⑥ ⑦

- ① Series No.
- ② Category: H-HSG
- ③ Welding Board Angle: Blank-ordinary
- ④ Row No.-Pin No.: XX-05P-25P
- ⑤ Plug the Pin & special No.: HF-Halogen Free
- ⑥ Material: LP-LCP 94V-0 ; N0-PA66 94V-0
- ⑦ Color: Blank-Natural Color

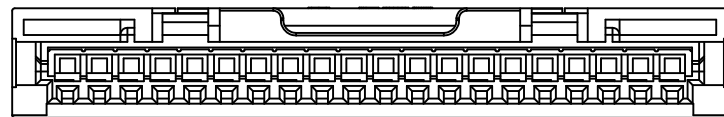

05P Scale 1:2

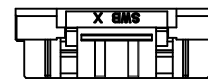

15P Scale 1:2

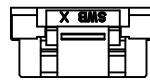

10P Scale 1:2

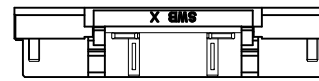

25P Scale 1:2

Poles	Dimensions(mm)		
	A	B	C
05	5.00	9.35	7.50
10	11.25	15.60	13.75
15	17.50	21.85	20.00
20	23.75	28.10	26.25
25	30.00	34.35	32.50

1257H-XXHF-LP	LCP UL 94V-0 Halogen Free	1257T	1257W
1257H-XXHF-N0	PA66 UL 94V-0 Halogen Free		
PART NO	Material	Suitable SWB Terminal	Mates With SWB Wafer

2014/06/04	A	B	Space of a Whole page Changes	Jova	Bob	
DATE	OLD REV	NEW REV		ECN	DESCRIPTION	CHECK

GENERAL TOLERANCE	
.X	±0.30
.XX	±0.20
.XXX	±0.10
PROJECT	

**SWB** 思索连接器有限公司  
TERMINAL & CONNECTORS SWB CONNECTORS CO.,LTD

APPROVAL	CHECK	DRAWN	DATA
Bob Sun	Jova Lau	Wuxiaotao	2014/06/04

PART NO. 1257H-XXHF-XX			
TITLE 1.25mm Crimp Style Connectors			
UNIT	SCALE	NUMBER	REV
MM	1:1	A-106	B

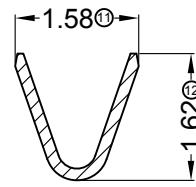
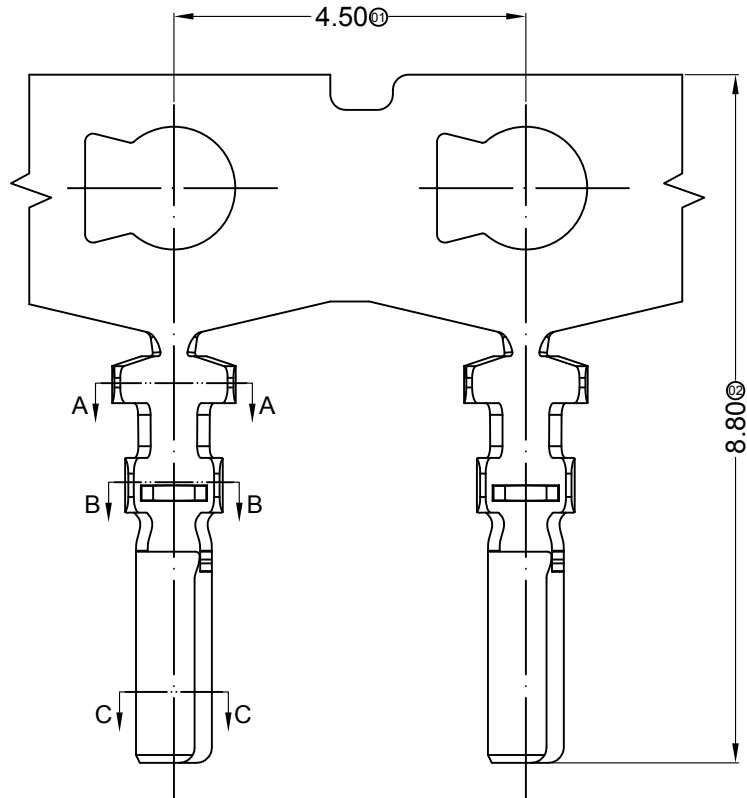

SECTION: A-A  
SCALE: 1:1

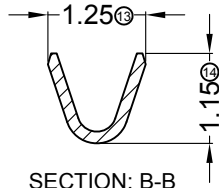

SECTION: B-B  
SCALE: 1:1

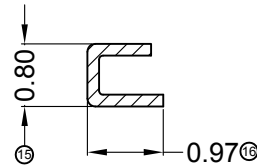
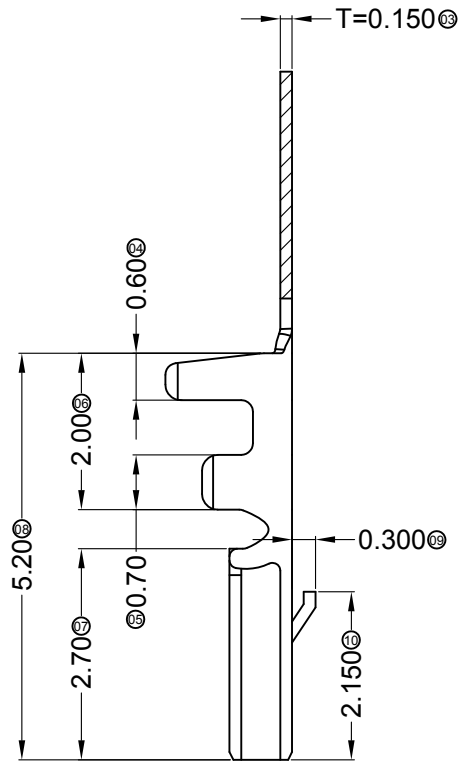

SECTION: C-C  
SCALE: 1:1

■ Specifications :

- Voltage rating: 200V AC / DC
- Current rating: 1.5A AC / DC
- Withstanding voltage: 1000V AC/minute
- Temperature range: -25°C~+130°C
- Insulation resistance: ≥1000MΩ
- Contact resistance: ≤20mΩ
- After environmental testing: ≤40mΩ

1257 T X-P SN X - X  
① ② ③ ④ ⑤ ⑥ ⑦

- ① Series Number
- ② Category: T-terminal
- ③ Shape: Blank-ordinary
- ④ Material: P-Phosphor bronze
- ⑤ Plating style: SN-Bright tin plating
- ⑥ Plating method: Blank-Stamping before plating
- ⑦ Mold No./Mark/Special No.

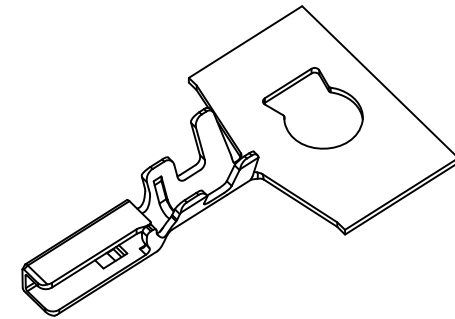

1257T-PSN	Phosphor Bronze	AWG#26-28	1.07mm(Max)	Stamping Before Plating:30u"MIN. Ni; 70u"Sn	1257H
PART NO	Material	Wire Range	Insulation O.D.	Finish	Used In SWB Housing

2014/06/04	A	B		Modify the drawing frame format	Jova	Bob
DATE	OLD REV	NEW REV	ECN	DESCRIPTION	CHECK	APPROVAL

GENERAL TOLERANCE  
 .X ±0.30  
 .XX ±0.20  
 .XXX ±0.10

PROJECT 

**SWB** 思索连接器有限公司  
 TERMINAL&CONNECTORS SWB CONNECTORS CO.,LTD

APPROVAL	CHECK	DRAWN	DATA
Bob Sun	Jova Lau	Wuxiaotao	2014/06/04

PART NO. 1257T-PSN			
TITLE 1.25mm Crimp Style Connectors			
UNIT	SCALE	NUMBER	REV
MM	1:1	A-106	B