

RoHS  Lead-free

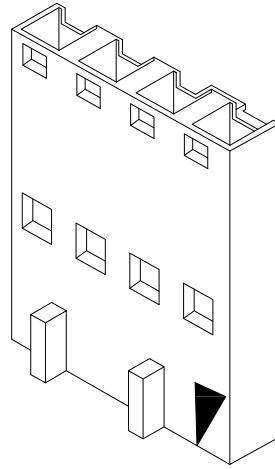

■ Specifications :

- Voltage rating: 250V AC / DC
- Current rating: 3A AC / DC
- Withstanding voltage: 1500V AC/minute
- Temperature range: -25°C~+85°C
- Insulation resistance: ≥1000MΩ
- Contact resistance: ≤20mΩ
- After environmental testing: ≤30mΩ
- Mark "\*" Indicate Dimensions Need To Controlled In Emphasis

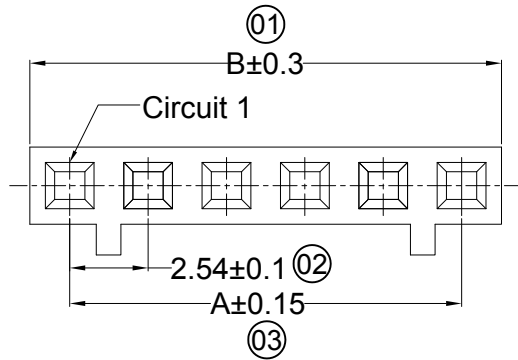
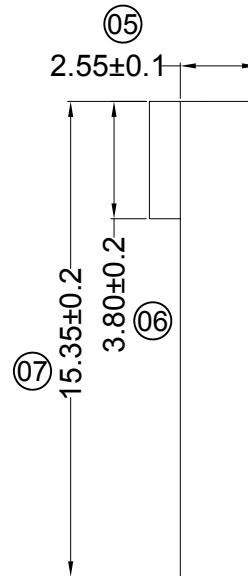
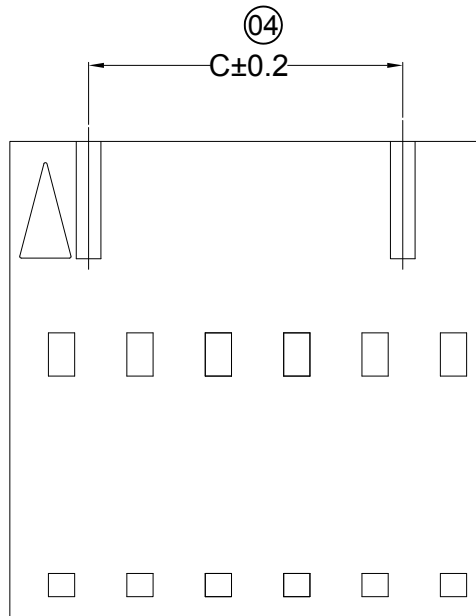

9556 H X-XX A-N0 XX

① ② ③ ④ ⑤ ⑥ ⑦

- ① Series No.
- ② Category:  
H-HSG
- ③ Welding Board Angle:  
Blank-ordinary
- ④ Row No.-Pin No.:  
XX-Single row
- ⑤ special No.  
A-There are convex point
- ⑥ Material:  
N0-PA66 94V-0
- ⑦ Color:  
Blank-Natural Color

Poles	Dimensions (mm)		
	A	B	C
2	2.54	5.08	--
3	5.08	7.62	2.54
4	7.62	10.16	5.08
5	10.16	12.70	7.62
6	12.70	15.24	10.16
7	15.24	17.78	12.70
8	17.78	20.32	15.24
9	20.32	22.86	17.78
10	22.86	25.40	20.32
11	25.40	27.94	22.86
12	27.94	30.48	25.40
13	30.48	33.02	27.94
14	33.02	35.56	30.48
15	33.02	38.10	33.02

9556H-XXA-N0	Nylon 66 UL 94V-0	9556T	9556W	1,000Pcs
PART NO	Material	Suitable SWB Terminal	Mates With SWB Wafer	Q' ty/Bag

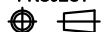
						GENERAL TOLERANCE		PART NO. 9556H-XXA-N0			
2013/08/16	B	C		Modify drawing frame format	Luna		.X ±0.30	TITLE 2.54 mm Crimp Style Connectors			
2011/06/30	A	B		Modify drawing frame format			.XX ±0.20	APPROVAL	CHECK	DRAWN	DATA
DATE	OLD REV	NEW REV	ECN	DESCRIPTION	CHECK	APPROVAL	.XXX ±0.10			Liu Yan	2007/05/03
							PROJECT	UNIT	SCALE	NUMBER	REV
								MM	1:1	A-106	C

**SWB** 东莞市思索连接器有限公司  
Terminal Connectors DongGuan Siweb Connectors CO.,LTD

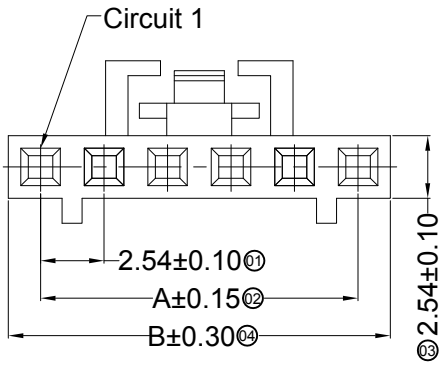

4P~20P Shape  
Scale 1:1

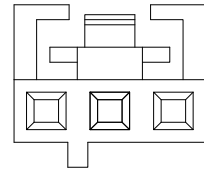

3P Shape  
Scale 1:1

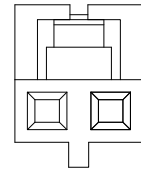

2P Shape  
Scale 1:1

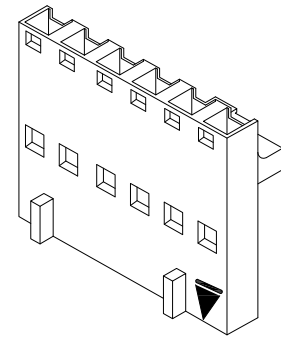

■ Specifications :

- Voltage rating: 250V AC / DC
- Current rating: 3A AC / DC
- Withstanding voltage: 1500V AC/minute
- Temperature range: -25°C~+85°C
- Insulation resistance: ≥1000MΩ
- Contact resistance: ≤20mΩ
- After environmental testing: ≤30mΩ

9556 H X-XX B-N0 XX

① ② ③ ④ ⑤ ⑥ ⑦

- ① Series No.
- ② Category: H-HSG
- ③ Welding Board Angle: Blank-ordinary
- ④ Row No.-Pin No.:XX-Single row
- ⑤ Special No.  
B-There are convex point and the buckle
- ⑥ Material: N0-PA66 94V-0
- ⑦ Color:  
Blank-Natural Color  
HF-Halogen free

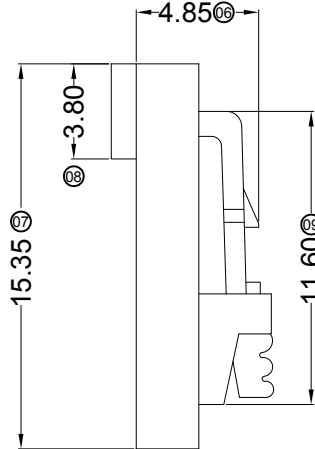
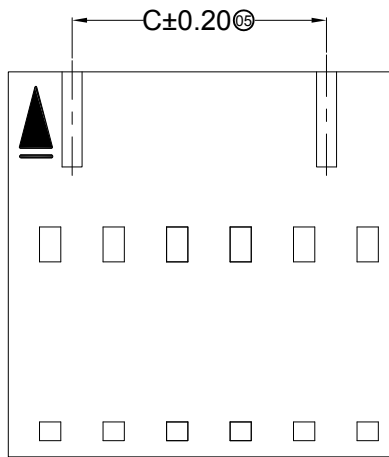

4P~20P

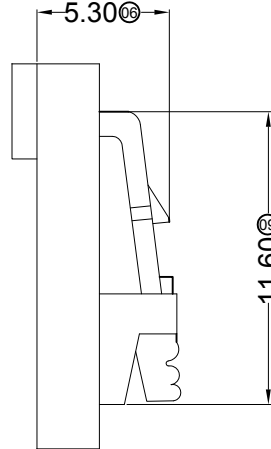

2P~03P

Poles	Dimensions(mm)			Poles	Dimensions(mm)		
	A	B	C		A	B	C
02	2.54	5.08	--	12	27.94	30.48	25.40
03	5.08	7.62	--	13	30.48	33.02	27.94
04	7.62	10.16	5.08	14	33.02	35.56	30.48
05	10.16	12.70	7.62	15	35.56	38.10	33.02
06	12.70	15.24	10.16	16	38.10	40.64	35.56
07	15.24	17.78	12.70	17	40.64	43.18	38.10
08	17.78	20.32	15.24	18	43.18	45.72	40.64
09	20.32	22.86	17.78	19	45.72	48.26	43.18
10	22.86	25.40	20.32	20	48.26	50.80	45.72
11	25.40	27.94	22.86				

9556H-XXB-N0HF	Nylon 66 UL 94V-0 Halogen Free	9556T	9556W
9556H-XXB-N0	Nylon 66 UL 94V-0		
PART NO	Material	Suitable SWB Terminal	Mates With SWB Wafer

2014/08/04	D	E		Space of a Whole page Changes	W.X.T		<b>GENERAL TOLERANCE</b> .X ±0.30 .XX ±0.20 .XXX ±0.10	 <b>思索连接器有限公司</b> SWB CONNECTORS CO.,LTD	PART NO. 9556H-XXB-N0XX						
2014/05/20	C	D		Change △C Dim	sylvia				TITLE 2.54 mm Crimp Style Connectors						
2013/08/16	B	C		Modify the drawing frame format	Luna				APPROVAL	CHECK	DRAWN	DATA			
DATE	OLD REV	NEW REV	ECN	DESCRIPTION	CHECK	APPROVAL	PROJECT			Wuxiaotao	2014/08/04	UNIT MM	SCALE 1:1	NUMBER A-106	REV E

RoHS  Lead-free

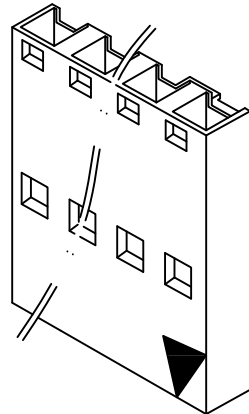
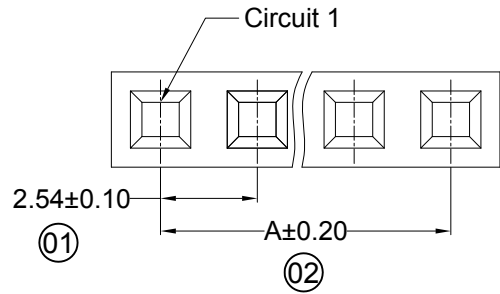

- Specifications :
- Voltage rating: 250V AC / DC
  - Current rating: 3A AC / DC
  - Withstanding voltage: 1500V AC/minute
  - Temperature range: -25°C~+85°C
  - Insulation resistance: ≥1000MΩ
  - Contact resistance: ≤20mΩ
  - After environmental testing: ≤30mΩ
  - Mark "\*" Indicate Dimensions Need To Controlled In Emphasis

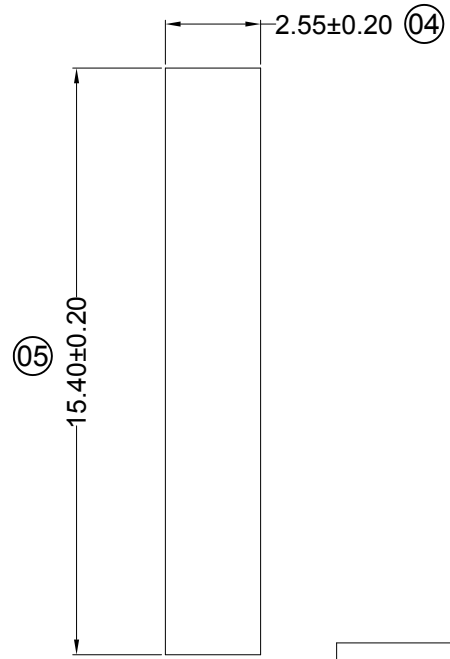
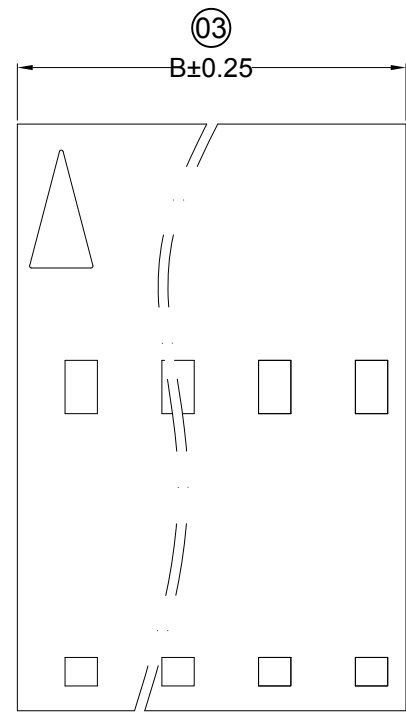

9556 H X-XX X-N0 XX  
 ① Series No.  
 ② Category: H-HSG  
 ③ Welding Board Angle: Blank-ordinary  
 ④ Row No.-Pin No.: XX-Single row  
 ⑤ special No.  
 ⑥ Material: N0-PA66 94V-0  
 ⑦ Color: Blank-Natural Color

Poles	Dimensions (mm)	
	A	B
2	2.54	5.15
3	5.08	7.69
4	7.62	10.23
5	10.16	12.77
6	12.70	15.31
7	15.24	17.85
8	17.78	20.39
9	20.32	22.93
10	22.86	25.47
11	25.40	28.01
12	27.94	30.55
13	30.48	33.09
14	33.02	35.63
15	35.56	38.18

9556H-XX-N0	Nylon 66 UL 94V-0	9556T	9556W	1,000Pcs
PART NO	Material	Suitable SWB Terminal	Mates With SWB Wafer	Q' ty/Bag

DATE	OLD REV	NEW REV	ECN	DESCRIPTION	CHECK	APPROVAL	PROJECT	APPROVAL	CHECK	DRAWN	DATA	UNIT	SCALE	NUMBER	REV
2013/08/16	B	C		Modify drawing frame format	Luna		GENERAL TOLERANCE					MM	1:1	A-005	C
2011/09/08	A	B		Modify drawing frame format			.X ±0.30								
							.XX ±0.20								
							.XXX ±0.10								

**SWB** 东莞市思索连接器有限公司  
 Terminal Connectors DongGuan Siweb Connectors CO.,LTD

APPROVAL: [Signature] CHECK: [Signature] DRAWN: Liu Yan DATA: 2007/05/03

PART NO. 9556H-XX-N0  
 TITLE 2.54 mm Crimp Style Connectors

RoHS  Lead-free

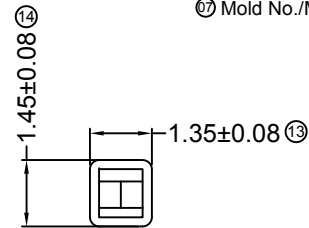
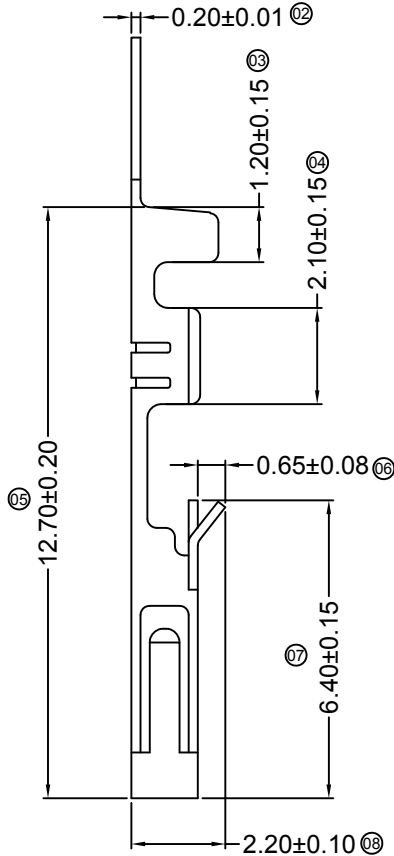
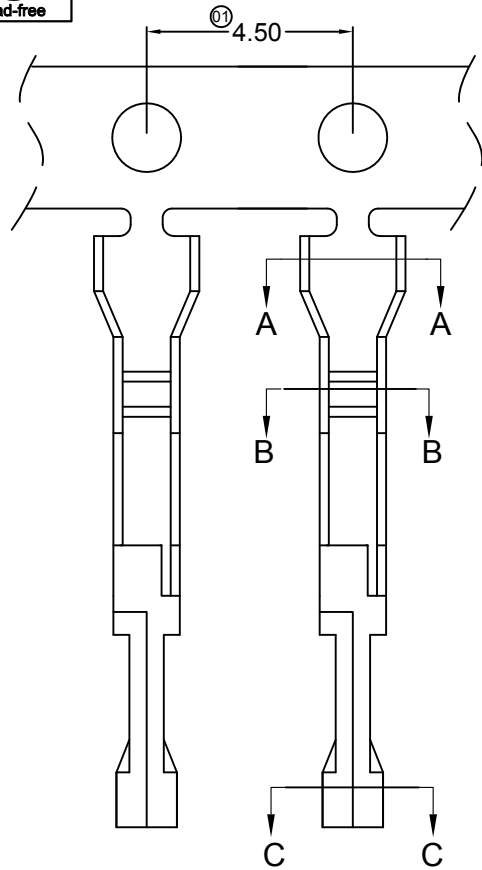

SECTION C-C  
SCALE 1 : 1

■ Specifications :

- Voltage rating: 250V AC / DC
- Current rating: 3A AC / DC
- Withstanding voltage: 1500V AC/minute
- Temperature range: -25°C~+85°C
- Insulation resistance: ≥1000MΩ
- Contact resistance: ≤20mΩ
- After environmental testing: ≤30mΩ

9556 T XX - X XX X - X  
① ② ③ ④ ⑤ ⑥ ⑦

- ① Series Number
- ② Category:T-terminal
- ③ Shape: Blank-ordinary
- ④ Material:  
P-Phosphor bronze ; B-brass
- ⑤ Plating style:  
G\*-Gold-Plated Contact  
\*01-Gold Flash ;  
\*15-15u"  
SN-Bright tin plating 70-120u"  
0-No plating material
- ⑥ Plating method:  
Blank-Stamping before plating  
B-Plating before stamping
- ⑦ Mold No./Mark/Special No.

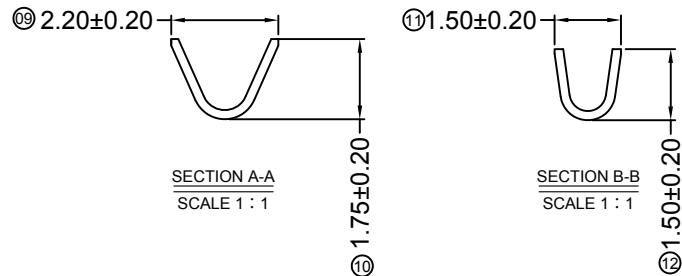

SECTION A-A  
SCALE 1 : 1

SECTION B-B  
SCALE 1 : 1

9556T-PG15	Phosphor Bronze	AWG#22-26	1.63mm(Max)	Stamping Before Pating:30~50u" Ni;Contact Area Gold:15u" Min.	9555H, 9556H	15,000Pcs
9556T-BG01	Brass	AWG#22-26	1.63mm(Max)	Stamping Before Pating:30~50u" Ni;Contact Area Gold Flash		
9556T-PG01	Phosphor Bronze	AWG#22-26	1.63mm(Max)	Stamping Before Pating:30~50u" Ni;Contact Area Gold Flash		
9556T-PSNB	Phosphor Bronze	AWG#22-26	1.63mm(Max)	Plating Before Stamping:10~30u" Ni;40~60u"Sn		
9556T-PSN	Phosphor Bronze	AWG#22-26	1.63mm(Max)	Stamping Before Plating:30~50u" Ni;70~120u"Sn		
PART NO	Material	Wire Range	Insulation O.D.	Finish	Used In SWB Housing	Q' ty/Reel

GENERAL TOLERANCE

.X ±0.30  
.XX ±0.20  
.XXX ±0.10

**SWB**  
Terminal & Connectors

思索连接器有限公司  
SWB CONNECTORS CO.,LTD

PART NO.

9556T-XX

TITLE

2.54 mm Crimp Style Connectors

APPROVAL CHECK DRAWN DATA

PROJECT

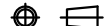

Allen 2013/11/29

UNIT	SCALE	NUMBER	REV
MM	1 : 1	A-002	A

DATE	OLD REV	NEW REV	ECN	DESCRIPTION	CHECK	APPROVAL

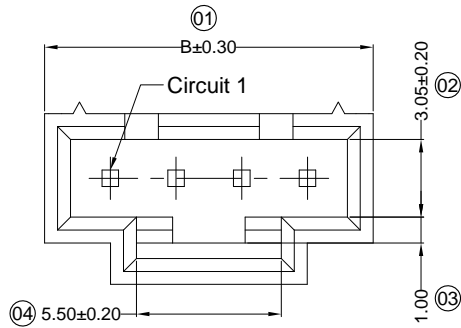

Recommend PCB Layout

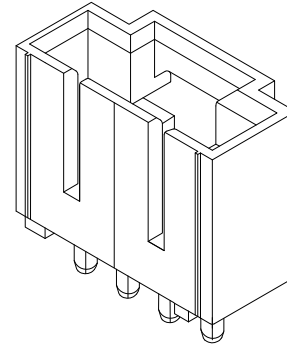
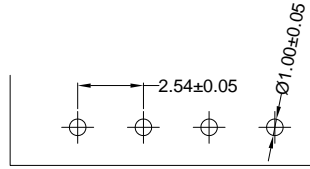

Specifications :

- Voltage rating: 250V AC / DC
- Current rating: 3A AC / DC
- Withstanding voltage: 1500V AC/minute
- Temperature range: -25°C~+85°C
- Insulation resistance: ≥1000MΩ
- Contact resistance: ≤20mΩ
- After environmental testing: ≤30mΩ

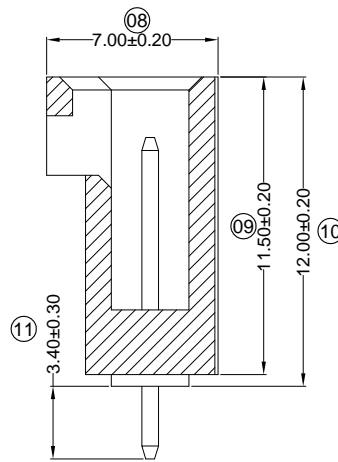
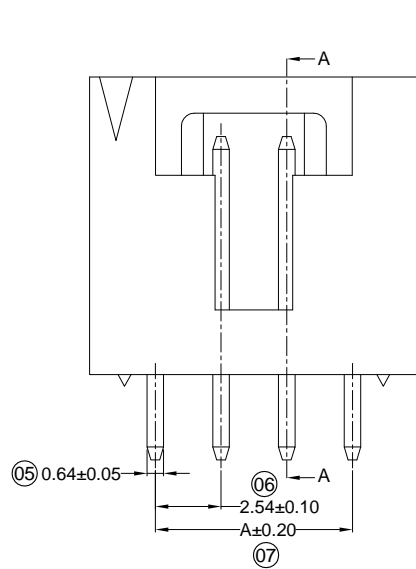

2P-6P

SECTION A-A  
SCALE 1 : 1

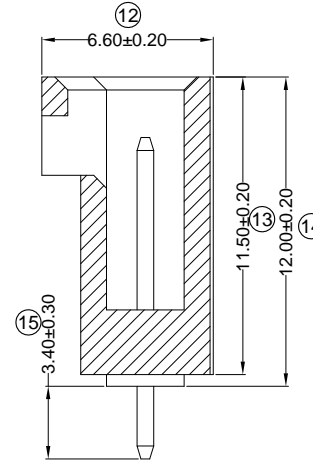

7P以上

SECTION A-A  
SCALE 1 : 1

9556 W V XX- XX X-XXXX XX  
① ② ③ ④ ⑤ ⑥ ⑦ ⑧ ⑨

- ① Series No.
- ② Category: W-wafer
- ③ Welding Board Angle: V-180°
- ④ Welding Way: Blank-DIP
- ⑤ Row No.-Pin No. XX-Single row
- ⑥ Special NO.
- ⑦ Material: N0-PA66 94V-0
- ⑧ Planting Category: V\*\*:All Gold-Plated  
\*01-Gold Flash ; \*02-2u" ; \*03-3u" ; \*05-5u" ; \*10-10u" ; \*15-15u" ; \*30-30u" ; \*50-50u" ; SN1-Bright tin plating 70-120u" ; SW-Fog Tin plating
- ⑨ Color: Blank-natural color

Poles	Dimensions (mm)	
	A	B
2	2.54	7.62
3	5.08	10.16
4	7.62	12.70
5	10.16	15.24
6	12.70	17.78
7	15.24	20.32
8	17.78	22.86
9	20.32	25.40
10	22.86	27.94
11	25.40	30.48
12	27.94	33.02
13	30.48	35.56
14	33.02	38.10
15	35.56	40.64
16	38.10	43.18
17	40.64	45.72
18	43.18	48.26
19	45.72	50.80
20	48.26	53.34
21	50.80	55.88
22	53.34	58.42
23	55.88	60.96
24	58.42	63.50

9556WV-XX-N0V15	Nylon 66 UL 94V-0	Brass	Gold-Plated 15u"	9556H	1,000Pcs
9556WV-XX-N0V01	Nylon 66 UL 94V-0	Brass	Gold-Flash		
PART NO	Material	Material(Pin)	Finish(Pin)	Mates With SWB Housing	Q' ty/Bag

DATE	OLD REV	NEW REV	ECN	DESCRIPTION	CHECK	APPROVAL	PROJECT	APPROVAL	CHECK	DRAWN	DATA	UNIT	SCALE	NUMBER	REV
2013/08/12	C	D		Modify drawing frame format	Luna		GENERAL TOLERANCE					MM	1 : 1	A-106	C
2012/03/06	B	C		Modify drawing frame format			.X ±0.30								
							.XX ±0.20								
							.XXX ±0.10								

**SWB** 东莞市思索连接器有限公司  
Terminal Connectors DongGuan Siweb Connectors CO.,LTD

PART NO. 9556WV-XX-XXXX  
TITLE 2.54 mm Crimp Style Connectors

**Specifications :**

- Voltage rating: 250V AC / DC
- Current rating: 3A AC / DC
- Withstanding voltage: 1500V AC/minute
- Temperature range: -25°C~+85°C
- Insulation resistance: ≥1000MΩ
- Contact resistance: ≤20mΩ
- After environmental testing: ≤30mΩ

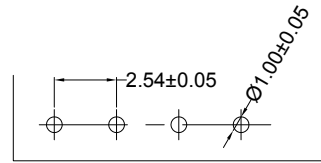
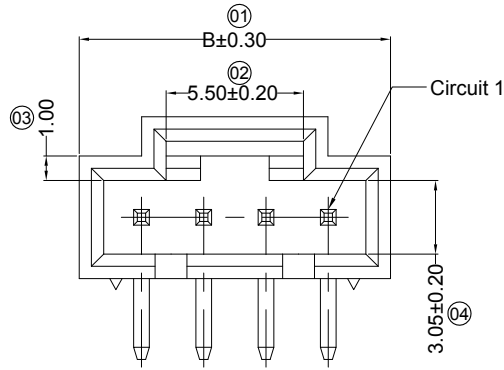

Recommend PCB Layout

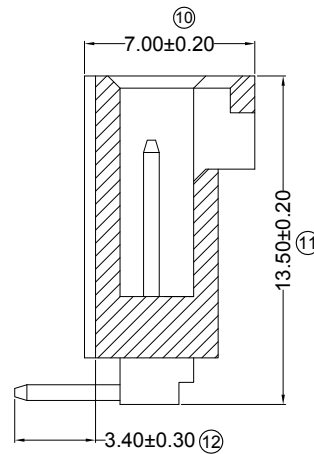
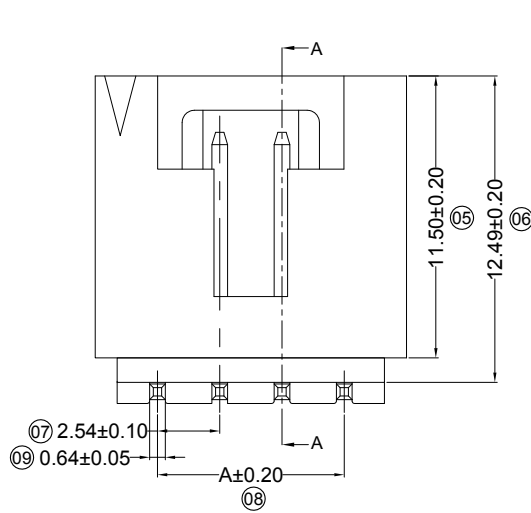
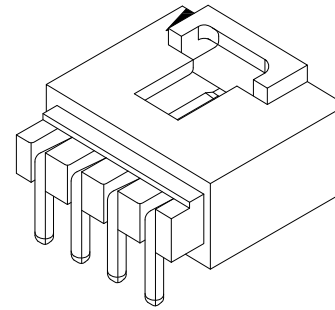

2P-6P  
SECTION A-A  
SCALE 1 : 1

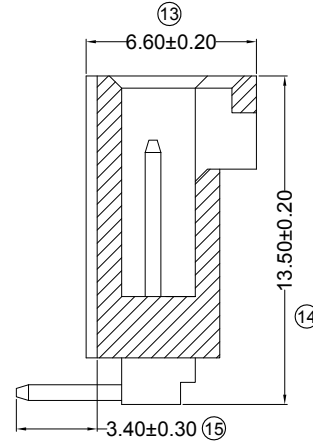

7P以上  
SECTION A-A  
SCALE 1 : 1

9556 W R XX- XX X-N0V01 XX

- ① Series No.
- ② Category: W-wafer
- ③ Welding Board Angle: R-90°
- ④ Welding Way: Blank-DIP
- ⑤ Row No.-Pin No. XX-Single row
- ⑥ Special NO.
- ⑦ Material: N0-PA66 94V-0
- ⑧ Planting Category: V\*\*:  
All Gold-Plated  
\*01-Gold Flash ; \*02-2u" ; \*03-3u" ; \*05-5u" ; \*10-10u" ; \*15-15u" ; \*30-30u" ; \*50-50u"  
SN-Bright tin plating 70-120u"  
SN1-Bright tin plating 120u"Min. ; SW-Fog Tin plating
- ⑨ Color: Blank-natural color

Poles	Dimensions (mm)	
	A	B
2	2.54	7.62
3	5.08	10.16
4	7.62	12.70
5	10.16	15.24
6	12.70	17.78
7	15.24	20.32
8	17.78	22.86
9	20.32	25.40
10	22.86	27.94
11	25.40	30.48
12	27.94	33.02
13	30.48	35.56
14	33.02	38.10
15	35.56	40.64
16	38.10	43.18
17	40.64	45.72
18	43.18	48.26
19	45.72	50.80
20	48.26	53.34
21	50.80	55.88
22	53.34	58.42
23	55.88	60.96
24	58.42	63.50

9556WR-XX-N0V01	Nylon 66 UL 94V-0	Brass	Gold-Flash	9556H	1,000Pcs
PART NO	Material	Material(Pin)	Finish(Pin)	Mates With SWB Housing	Q' ty/Bag

DATE	OLD REV	NEW REV	ECN	DESCRIPTION	CHECK	APPROVAL	PROJECT	APPROVAL	CHECK	DRAWN	DATA	UNIT	SCALE	NUMBER	REV
2013/08/12	B	C	ECN2013082501	Modify drawing frame format	Luna		GENERAL TOLERANCE					MM	1 : 1	A-106	C
2012/03/06	A	B		Modify drawing frame format			.X ±0.30								
							.XX ±0.20								
							.XXX ±0.10								

**SWB** 东莞市思索连接器有限公司  
Terminal Connectors DongGuan Siweb Connectors CO.,LTD

PART NO. 9556WR-XX-N0V01  
TITLE 2.54 mm Crimp Style Connectors

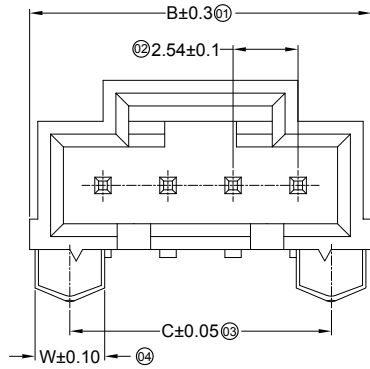

9556WRS-XX-LPV01	W=2.7
9556WRS-XXA-LPV01	W=3.12

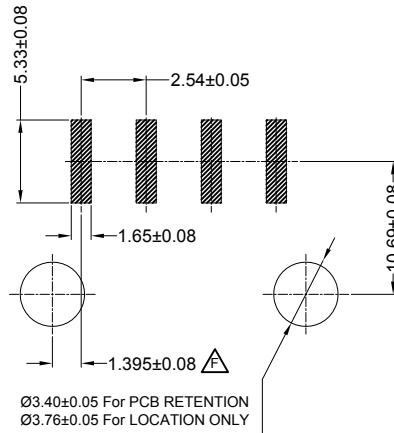
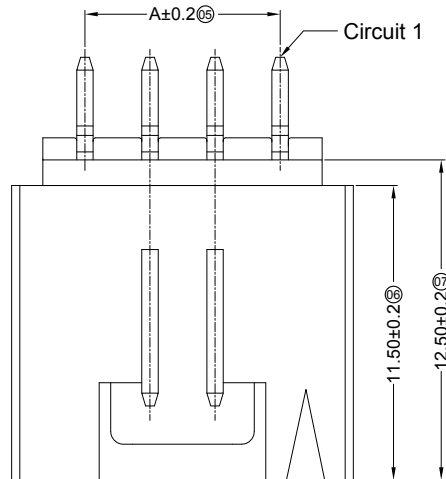
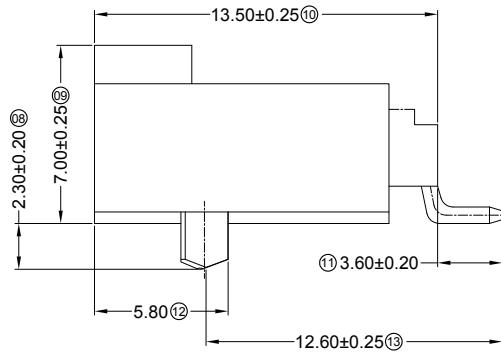

Recommand PCB Layout

■ Specifications :

- Voltage rating: 250V AC / DC
- Current rating: 3A AC / DC
- Withstanding voltage: 1500V AC/minute
- Temperature range: -40°C~+105°C
- Insulation resistance: ≥1000M<sub>Ω</sub>/E
- Contact resistance: ≤20m<sub>Ω</sub>/E
- After environmental testing: ≤30m<sub>Ω</sub>/E

9556 W R S- XX-XX LP XX XX

① ② ③ ④ ⑤ ⑥ ⑦ ⑧ ⑨

- ① Series No.
- ② Category: W-wafer
- ③ Welding Board Angle: R-90°
- ④ Welding Way: S-SMT
- ⑤ Row No.-Pin No.: XX-Single row
- ⑥ Special NO. Blank: W=2.7 A: W=3.12
- ⑦ Material: LP-LCP 94V-0
- ⑧ Planting Category:  
V\*\*:All Gold-Plated \*01-Gold Flash  
SW-Matte Tin plating
- ⑨ Color:  
Blank-Natural Color Black

Poles	Dimensions (mm)			Poles	Dimensions (mm)		
	A	B	C		A	B	C
02	2.54	8.89	5.33	08	17.78	24.13	20.57
03	5.08	11.43	7.87	09	20.32	26.67	23.11
04	7.62	13.97	10.41	10	22.86	29.21	25.65
05	10.16	16.51	12.95	11	25.40	31.75	28.19
06	12.70	19.05	15.49	12	27.94	34.29	30.73
07	15.24	21.59	18.03				

9556WRS-XXX-LPSW	LCP UL 94V-0	Brass	Matte tin	9556H
9556WRS-XXA-LPV01			Gold-Flash	
9556WRS-XX-LPV01				
PART NO	Material	Material(Pin)	Finish(Pin)	Mates With SWB Housing

2014/01/17	D	E		Change PCB Layout DIM	Jova		<b>GENERAL TOLERANCE</b> .X ±0.30 .XX ±0.20 .XXX ±0.10	 <b>思索连接器有限公司</b> <b>SWB CONNECTORS CO.,LTD</b>	PART NO. 9556WRS-XXX-LPXX						
2014/01/09	C	D	ECN2013082501	Add Post Pitch Size and Change "B" size	Jova				TITLE 2.54 mm Crimp Style Connectors						
2014/02/07	E	F		Change PCB Layout DIM and Material Color	Jova				APPROVAL	CHECK	DRAWN	DATA			
DATE	OLD REV	NEW REV	ECN	DESCRIPTION	CHECK	APPROVAL	PROJECT	Success	Sun Kaibao	Liu Yan	2007/05/03	UNIT MM	SCALE 1:1	NUMBER A-106	REV F

RoHS  Lead-free

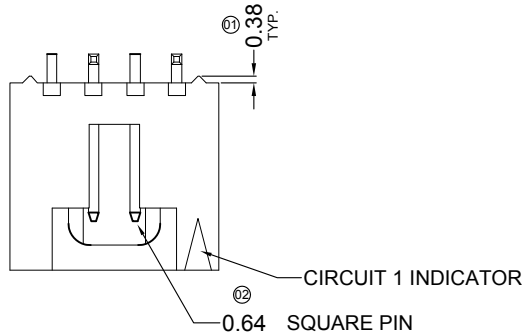

### Specifications :

- Voltage rating: 250V AC / DC
- Current rating: 3A AC / DC
- Withstanding voltage: 1500V AC/minute
- Temperature range: -25°C~+85°C
- Insulation resistance: ≥1000MΩ
- Contact resistance: ≤20mΩ
- After environmental testing: ≤30mΩ

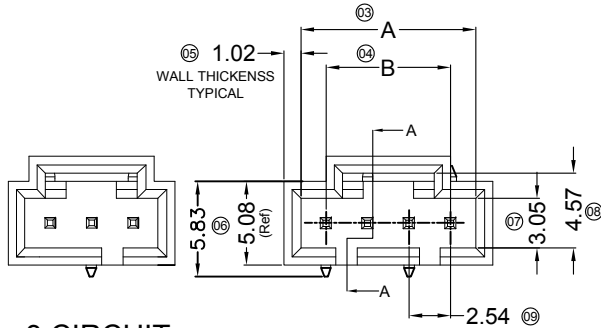

3 CIRCUIT

4 CIRCUIT SHOWN

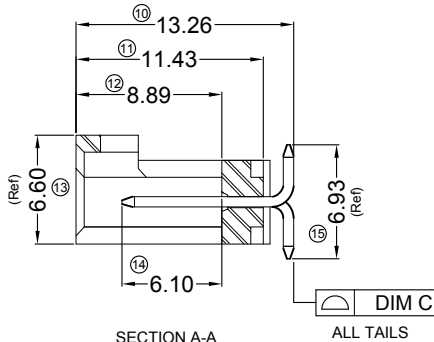

SECTION A-A  
SCLAE 1:1

9556 W V S - XX X-9TV01 XX

① ② ③ ④ ⑤ ⑥ ⑦ ⑧ ⑨

- ① Series No.
- ② Category: W-wafer
- ③ Welding Board Angle: V-180°
- ④ Welding Way: S-SMT
- ⑤ Row No.-Pin No. XX-Single row
- ⑥ Special NO.
- ⑦ Material: 9T-PA9T 94V-0
- ⑧ Planting Category: V\*\* : All Gold-Plated  
\*01-Gold Flash ; \*02-2u" ; \*03-3u" ; \*05-5u" ; \*10-10u" ; \*15-15u" ; \*30-30u" ; \*50-50u"  
SN-Bright tin plating 70-120u"  
SN1-Bright tin plating 120u"Min. ; SW-Fog Tin plating
- ⑨ Color: Blank-natural color

Poles	Dimension(mm)		
	A	B	C
3	8.13	5.08	0.15
4	10.67	7.62	0.15
5	13.21	10.16	0.15
6	15.75	12.70	0.15
7	18.29	15.24	0.15
8	20.83	17.78	0.15
9	23.37	20.32	0.15
10	25.91	22.86	0.15
11	28.45	25.40	0.15
12	30.99	27.94	0.15
13	33.53	30.48	0.15
14	36.07	33.02	0.15
15	38.61	35.56	0.15
16	41.15	38.10	0.15
17	43.69	40.64	0.15
18	46.23	43.18	0.15
19	48.77	45.72	0.15
20	51.31	48.26	0.18
21	53.85	50.80	0.18
22	56.39	53.34	0.18
23	58.93	55.88	0.18
24	61.47	58.42	0.18
25	64.01	60.96	0.18

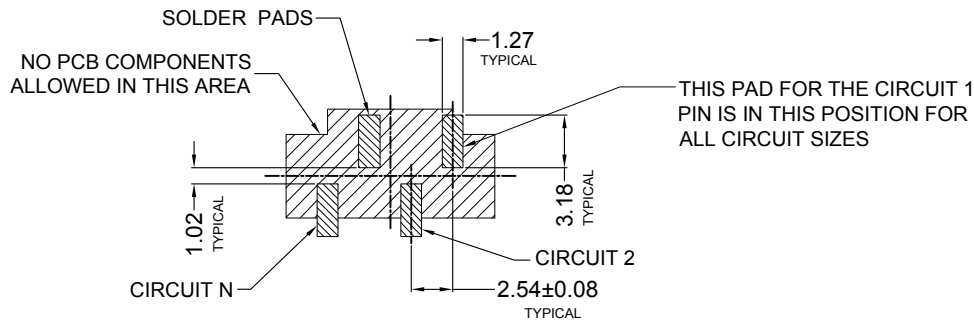

RECOMMENDED PC BOARD LAYOUT

9556WVS-XX-9TV01	PA9T UL 94V-0	Brass	Gold-Flash	9556H
PART NO	Material	Material(Pin)	Finish(Pin)	Mates With SWB Housing

GENERAL TOLERANCE

.X ±0.30  
.XX ±0.20  
.XXX ±0.10



思索连接器有限公司  
SWB Connectors CO.,LTD

PART NO.

9556WVS-XX-9TV01

TITLE

2.54mm Crimp Style Connectors

DATE	OLD REV	NEW REV	ECN	DESCRIPTION	CHECK	APPROVAL

PROJECT
Bob

APPROVAL	CHECK	DRAWN	DATA
Bob	Jova	yangmei	2013.12.23

UNIT	SCALE	NUMBER	REV
MM	1:1	A-106	A



RoHS Lead-free

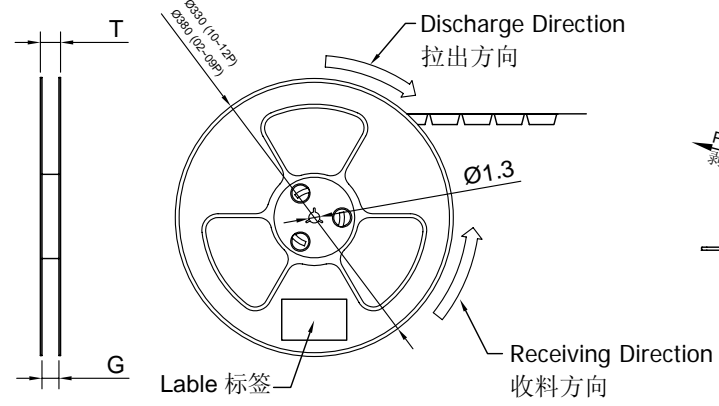
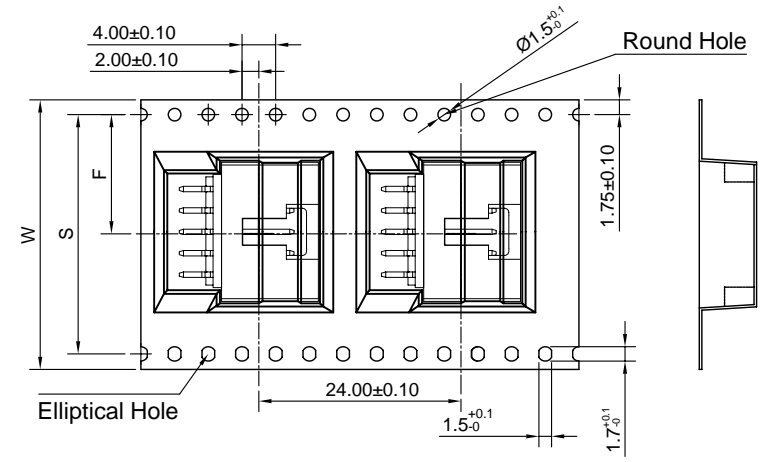
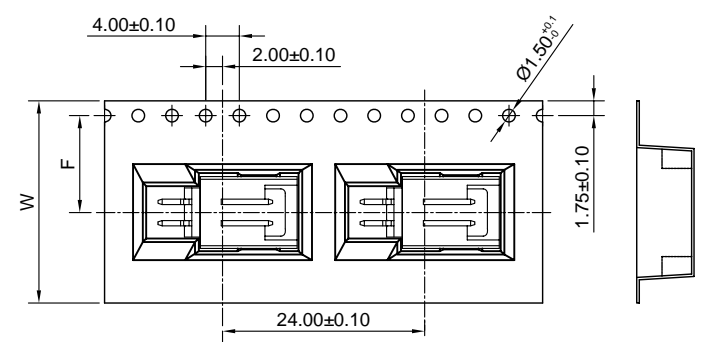
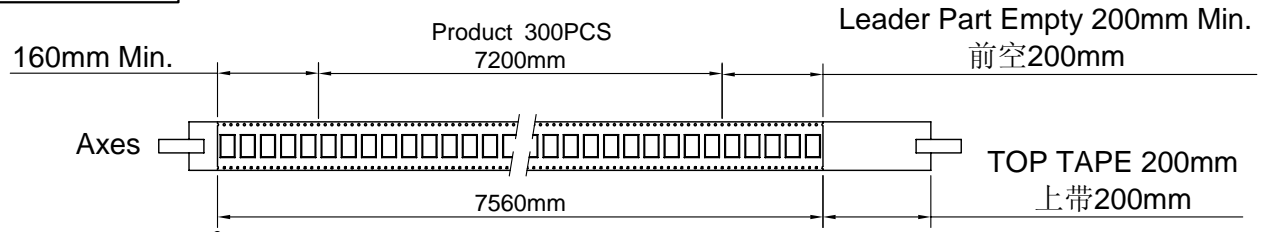

COVER TAPE PEEL STRENGTH: 20~120g  
 上带剥离力量: 20~120g  
 速度 PEEL SPEED: 300mm/minute

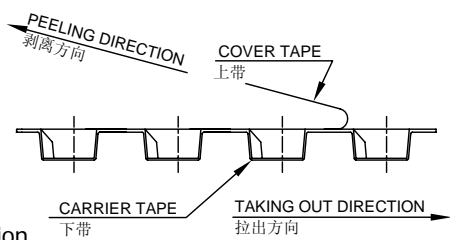

Lable 标签  
 Single hole: None Hole Side  
 单孔: 贴无链孔侧  
 Double hole: Elliptical Hole Side  
 双孔: 贴椭圆孔侧

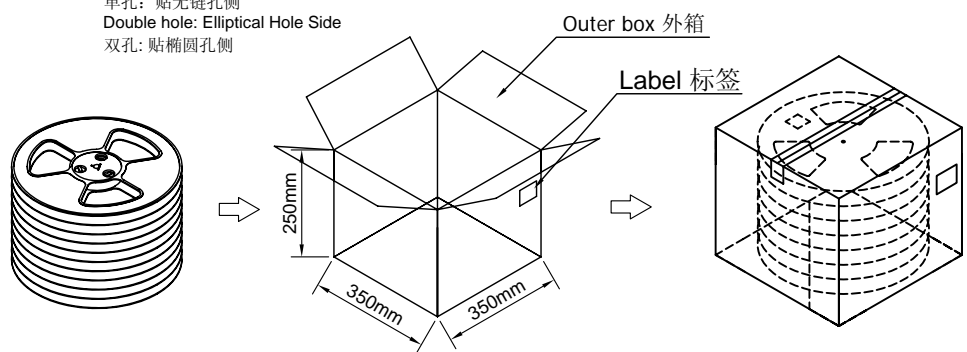

	Pin No.	W	S	F	T	G	REEL /PCS	CARTON /R	CARTON /PCS
ZD9556WRS-XX 9556WRS-XX-XXXX	ZD9556WRS-02	24	/	11.50	29.5	25.5	300	8	2400
	ZD9556WRS-03								
	ZD9556WRS-04								
	ZD9556WRS-05	32	28.4	15.50	37.5	33.5	300	6	1800
	ZD9556WRS-06								
	ZD9556WRS-07								
	ZD9556WRS-08	44	36.4	19.50	48.5	44.5	300	4	1200
	ZD9556WRS-09								
	ZD9556WRS-10								
	ZD9556WRS-11	56	44.4	23.50	60.5	56.5	300	3	900
	ZD9556WRS-12								

- Note:**
- Carrier Camber Is Within 1mm In 100mm ; 带长100mm内容许弯曲度1mm
  - 10 Sprocket Hole Pitch Cumulative Tolerance±0.2MM ; 圆孔十个孔距离累计允许公差为±0.2mm
  - Material for PS ; 材质为PS材质
  - Thickness=0.50±0.05 ; 材料厚度为0.50±0.05mm

							GENERAL TOLERANCE				PART NO. PPN: 9556WRS-XX-XXXX CPN: ZD9556WRS-XX				
							.X ±0.30				TITLE				
							.XX ±0.20				2.54mm Connectors 90° Package				
							.XXX ±0.10				APPROVAL CHECK DRAWN DATA				
DATE	OLD REV	NEW REV	ECN	DESCRIPTION	CHECK	APPROVAL	PROJECT					UNIT MM	SCALE 1:1	NUMBER A-106	REV B
										Allen	2013/12/09				

**SWB** 思索连接器有限公司  
 SWB CONNECTORS CO.,LTD

RoHS  Lead-free

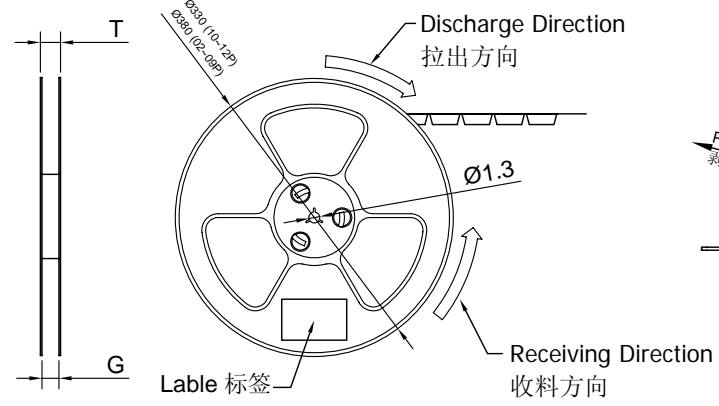
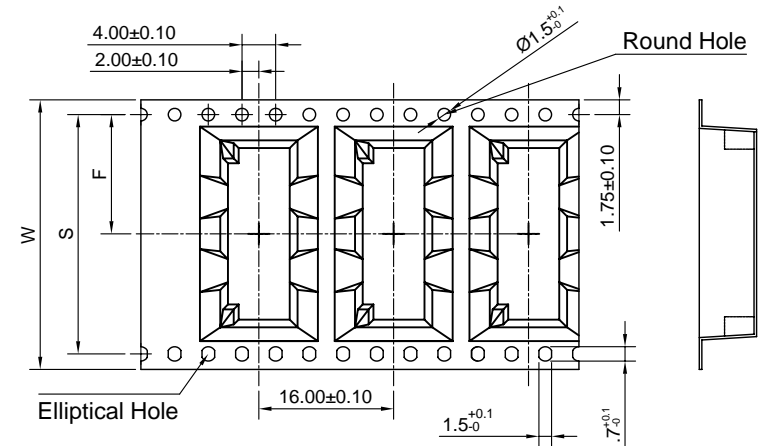
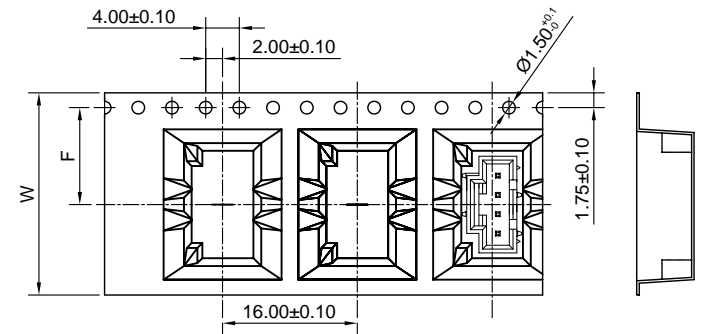
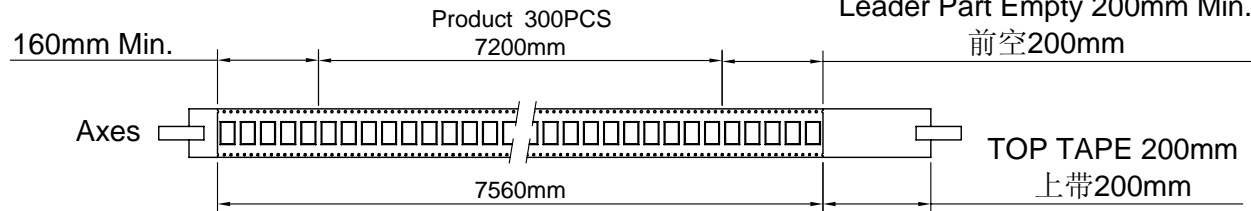

COVER TAPE PEEL STRENGTH: 20~120g  
 上带剥离力量: 20~120g  
 速度 PEEL SPEED: 300mm/minute

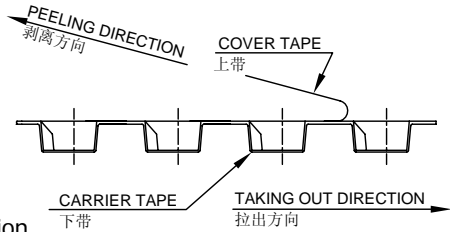

Single hole: None Hole Side  
 单孔: 贴无键孔侧  
 Double hole: Elliptical Hole Side  
 双孔: 贴椭圆孔侧

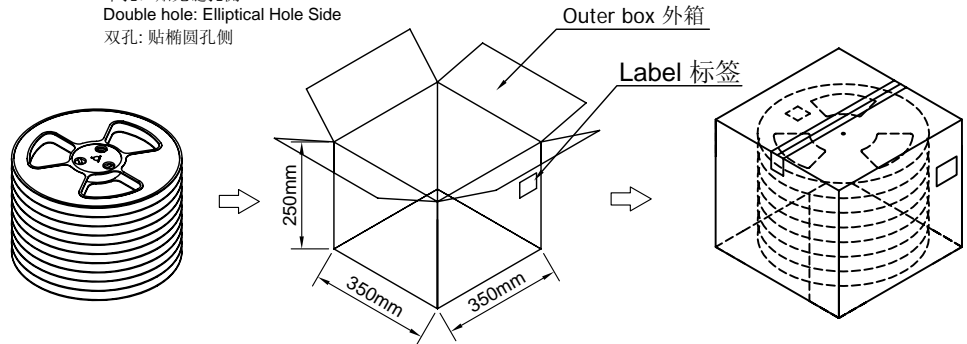

	Pin No.	W	S	F	T	G	REEL /PCS	CARTON /R	CARTON /PCS
ZD9556WVS-XX 9556WVS-XX-XXXX	ZD9556WVS-02	24	/	11.50	29.5	25.5	300	8	2400
	ZD9556WVS-03								
	ZD9556WVS-04								
	ZD9556WVS-05	32	28.4	15.50	37.5	33.5	300	6	1800
	ZD9556WVS-06	44	36.4	19.50	48.5	44.5	300	4	1200
	ZD9556WVS-07								
	ZD9556WVS-08								
	ZD9556WVS-09	56	44.4	23.50	60.5	56.5	300	3	900
	ZD9556WVS-10								
	ZD9556WVS-11								
	ZD9556WVS-12								

- Note:**
- Carrier Camber Is Within 1mm In 100mm ; 带长100mm内容许弯曲度1mm
  - 10 Sprocket Hole Pitch Cumulative Tolerance±0.2MM ; 圆孔十个孔距离累计允许公差为±0.2mm
  - Material for PS ; 材质为PS材质
  - Thickness=0.50±0.05 ; 材料厚度为0.50±0.05mm

							GENERAL TOLERANCE		SWB 思索连接器有限公司 SWB CONNECTORS CO.,LTD				PART NO. PPN: 9556WVS-XX-XXXX CPN: ZD9556WVS-XX					
							.X	±0.30	APPROVAL		CHECK	DRAWN	DATA		TITLE 2.54mm Connectors 180° Package			
DATE	OLD REV	NEW REV	ECN	DESCRIPTION	CHECK	APPROVAL	PROJECT				Allen	2013/12/09		UNIT	SCALE	NUMBER	REV	
														MM	1:1	A-106	B	