

**Specifications :**

- Voltage rating: 100V AC / DC
- Current rating: 2A AC / DC
- Withstanding voltage: 800V AC/minute
- Temperature range: -25°C~+85°C
- Insulation resistance: ≥1000MΩ
- Contact resistance: ≤10mΩ
- After environmental testing: ≤20mΩ

2016 H X-XX X-N0 HF-C  
① ②③ ④ ⑤ ⑥ ⑦ ⑧

- ① Series No.
- ② Category: H-HSG
- ③ Appearance type: Blank-Ordinary
- ④ Row No.-Pin No.: XX-02P~20P
- ⑤ Plug the Pin & special No.: Blank-Ordinary
- ⑥ Material: N0-PA66 94V-0
- ⑦ HF-Halogen Free
- ⑧ C-Glowing Filament ;

Poles	Dimensions (mm)			Poles	Dimensions (mm)		
	A	B	C		A	B	C
02	2.00	5.80	4.60	12	22.00	25.80	24.60
03	4.00	7.80	6.60	13	24.00	27.80	26.60
04	6.00	9.80	8.60	14	26.00	29.80	28.60
05	8.00	11.80	10.60	15	28.00	31.80	30.60
06	10.00	13.80	12.60	16	30.00	33.80	32.60
07	12.00	15.80	14.60	17	32.00	35.80	34.60
08	14.00	17.80	16.60	18	34.00	37.80	36.60
09	16.00	19.80	18.60	19	36.00	39.80	38.60
10	18.00	21.80	20.60	20	38.00	41.80	40.60
11	20.00	23.80	22.60				

2016H-XX-N0-C	Nylon 66 UL 94V-0	2016T	2016W
2016H-XX-N0HF	PA66 UL 94V-0 Halogen Free		
2016H-XX-N0	Nylon 66 UL 94V-0		
PART NO	Material	Suitable SWB Terminal	Mates With SWB Wafer

DATE	OLD REV	NEW REV	ECN	DESCRIPTION	CHECK	APPROVAL	PROJECT
2014/06/13	C	D		Space of a Whole page Changes	Jova	Bob	

GENERAL TOLERANCE  
.X ±0.30  
.XX ±0.20  
.XXX ±0.10



APPROVAL	CHECK	DRAWN	DATA
Bob Sun	Jova Lau	Wuxiaotao	2014/06/13

PART NO.			
2016H-XX-N0XX			
TITLE			
2.00mm Crimp Style Connectors			
UNIT	SCALE	NUMBER	REV
MM	1:1	A-039	D

■ Specifications :

- Voltage rating: 100V AC / DC
- Current rating: 2A AC / DC
- Withstanding voltage: 800V AC/minute
- Temperature range: -25°C~+85°C
- Insulation resistance: ≥1000MΩ
- Contact resistance: ≤10mΩ
- After environmental testing: ≤20mΩ

2016 T X-P XXX X - X  
 ① ② ③ ④ ⑤ ⑥ ⑦

- ① Series Number
- ② Category: T-terminal
- ③ Shape: Blank-ordinary
- ④ Material: P-Phosphor bronze
- ⑤ Plating style: V01-Gold Flash ; SN-Bright tin plating
- ⑥ Plating method: Blank-Stamping before plating  
B-Plating before stamping
- ⑦ Mold No./Mark/Special No.

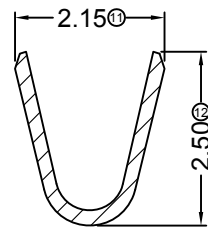
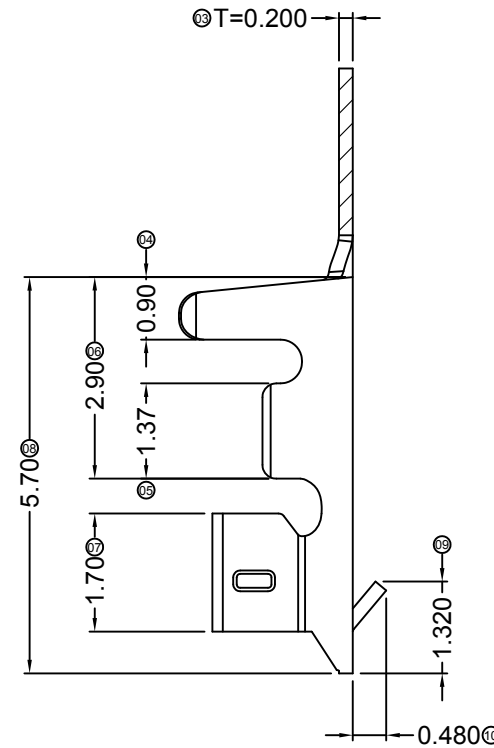
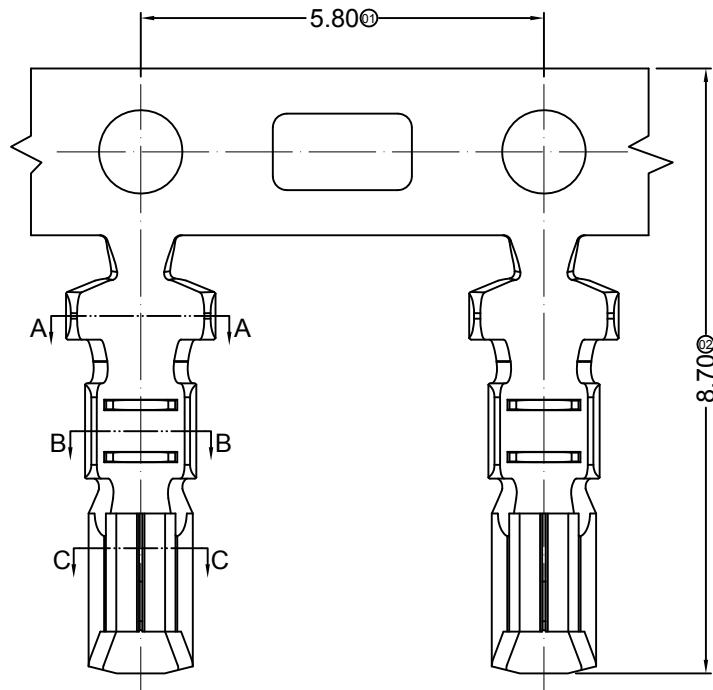

SECTION: A-A  
SCALE: 1:1

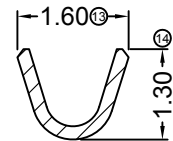

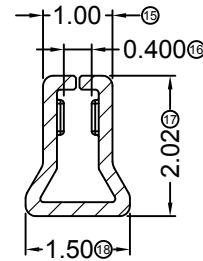

SECTION: B-B  
SCALE: 1:1

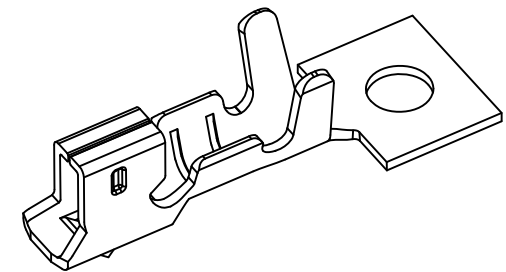

SECTION: C-C  
SCALE: 1:1



2016T-PV01				Stamping Before plating:30u" MIN. Ni; Whole Gold :Gold Flash	
2016T-PSNB	Phosphor Bronze	AWG#22-28	1.50mm(Max)	Plating Before Stamping:10u" MIN. Ni ; 30u"Sn	2016H
2016T-PSN				Stamping Before plating:30u" MIN. Ni; 70u"Sn	
PART NO	Material	Wire Range	Insulation O.D.	Finish	Used In SWB Housing

							<b>GENERAL TOLERANCE</b> .X ±0.30 .XX ±0.20 .XXX ±0.10				 <b>思索连接器有限公司</b> SWB CONNECTORS CO.,LTD				<b>PART NO.</b> 2016T-PXXXX			
							<b>APPROVAL</b> Bob Sun <b>CHECK</b> Jova Lau <b>DRAWN</b> Wuxiaotao <b>DATA</b> 2014/06/16				<b>TITLE</b> 2.00 mm Crimp Style Connectors							
2014/06/16	C	D		Modify the drawing frame format	Jova	Bob												
<b>DATE</b>	<b>OLD REV</b>	<b>NEW REV</b>	<b>ECN</b>	<b>DESCRIPTION</b>	<b>CHECK</b>	<b>APPROVAL</b>	<b>PROJECT</b>					<b>UNIT</b>	<b>SCALE</b>	<b>NUMBER</b>	<b>REV</b>			
								Bob Sun	Jova Lau	Wuxiaotao	2014/06/16	MM	1 : 1	A-039	D			

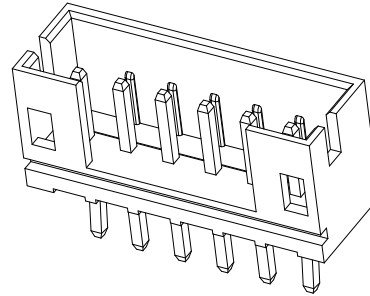
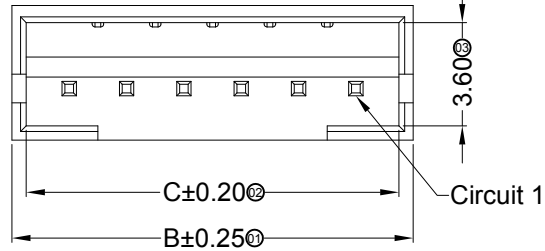

■ Specifications :

- Voltage rating: 100V AC / DC
- Current rating: 2A AC / DC
- Withstanding voltage: 800V AC/minute
- Temperature range: -25°C~+85°C
- Insulation resistance: ≥1000MΩ
- Contact resistance: ≤10mΩ
- After environmental testing: ≤20mΩ

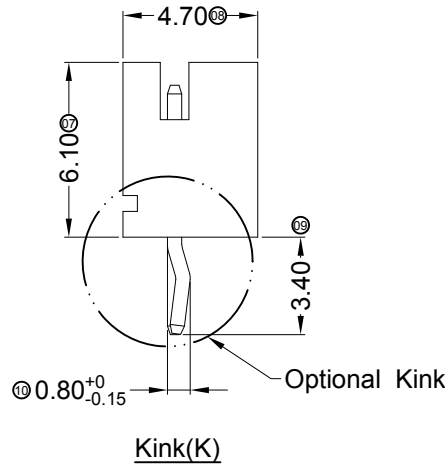
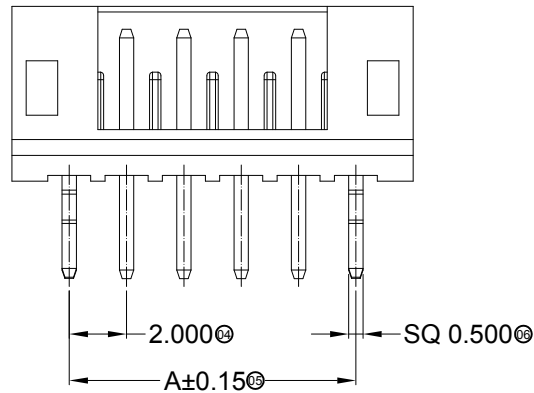

2016 W V X-XX KX -N0 SN XX  
 ① ② ③ ④ ⑤ ⑥ ⑦ ⑧ ⑨

- ① Series No.
- ② Category: W-WAFER
- ③ Welding Board Angle: V-Straight 180°
- ④ Welding Way: Blank-DIP
- ⑤ Row No.-Pin No.: XX-02P~20P
- ⑥ Plug the Pin & Special No.: K-Kink ; K1- Reverse Kink ;
- ⑦ Material: 46 -PA46 94V-0 ; N0-PA66 94V-0
- ⑧ Plating Category: SN-Bright Tin Plating ; V01-Gold Flash
- ⑨ Color : Blank-Natural Color ; GY-Gray

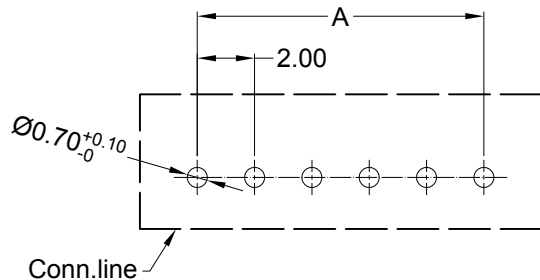

Recommended P.C.B Layout  
 General Tolerance±0.05

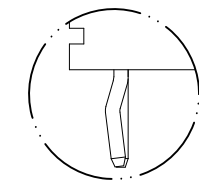

Reverse Kink(K1)

Poles	Dimensions (mm)			Poles	Dimensions (mm)			Poles	Dimensions (mm)		
	A	B	C		A	B	C		A	B	C
02	2.00	6.00	5.00	09	16.00	20.00	19.00	16	30.00	34.00	33.00
03	4.00	8.00	7.00	10	18.00	22.00	21.00	17	32.00	36.00	35.00
04	6.00	10.00	9.00	11	20.00	24.00	23.00	18	34.00	38.00	37.00
05	8.00	12.00	11.00	12	22.00	26.00	25.00	19	36.00	40.00	39.00
06	10.00	14.00	13.00	13	24.00	28.00	27.00	20	38.00	42.00	41.00
07	12.00	16.00	15.00	14	26.00	30.00	29.00				
08	14.00	18.00	17.00	15	28.00	32.00	31.00				

2016WV-XXXK-46SNGY	Nylon 46 UL 94V-0 Gray	Brass	Tin-Plated	2016H
2016WV-XXXK-N0V01	Nylon 66 UL 94V-0		Gold-Flash	
2016WV-XXXK-N0SN			Tin-Plated	
PART NO	Material	Material(Pin)	Finish(Pin)	Mates With SWB Housing

DATE	OLD REV	NEW REV	ECN	DESCRIPTION	CHECK	APPROVAL	PROJECT	APPROVAL	CHECK	DRAWN	DATA	UNIT	SCALE	NUMBER	REV
2014/06/18	C	D		Modify the drawing frame format	Wuxiaotao	Jova	GENERAL TOLERANCE					MM	1:1	A-003	D
2014/03/21	B	C		According to the system change K feet	sylvia	Jova	.X ±0.30								
							.XX ±0.20								
							.XXX ±0.10								
										Jova	2012/11/22				

**SWB** 思索连接器有限公司  
 Terminal & Connectors SWB CONNECTORS CO., LTD

PART NO. 2016WV-XXXK-XXXXX

TITLE 2.00 mm Crimp Style Connectors

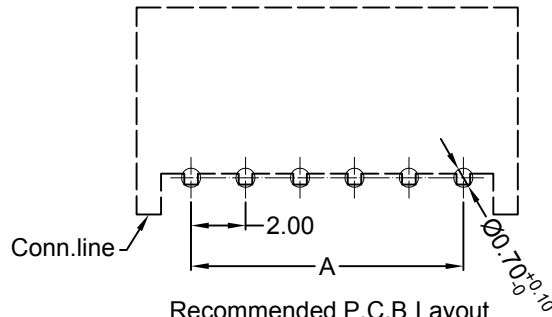
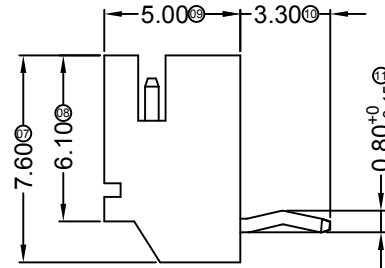
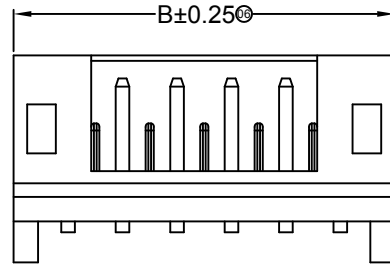
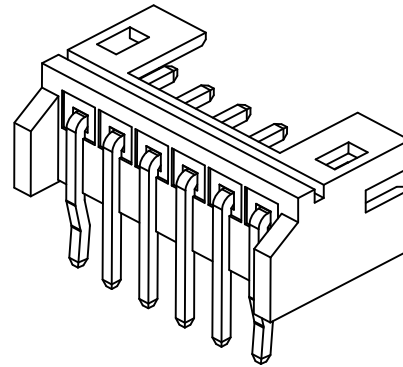
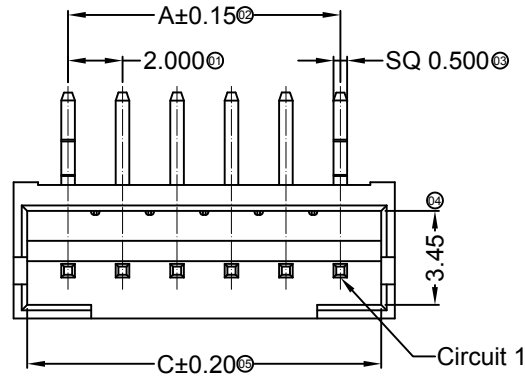

Recommended P.C.B Layout  
General Tolerance±0.05

■ Specifications :

- Voltage rating: 100V AC / DC
- Current rating: 2A AC / DC
- Withstanding voltage: 800V AC/minute
- Temperature range: -25°C~+85°C
- Insulation resistance: ≥1000MΩ
- Contact resistance: ≤10mΩ
- After environmental testing: ≤20mΩ

2016 W R X-XX K -N0 SN XX  
① ② ③ ④ ⑤ ⑥ ⑦ ⑧ ⑨

- ① Series No.
- ② Category: W-WAFER
- ③ Welding Board Angle: R-Right Angle 90°
- ④ Welding Way: Blank-DIP
- ⑤ Row No.-Pin No.: XX-02P~20P
- ⑥ Plug the Pin & Special No.: K-Kink, DIP=3.30mm
- ⑦ Material: N0-PA66 94V-0
- ⑧ Plating Category: SN-Bright Tin Plating
- ⑨ Color : Blank-Natural Color;

Poles	Dimensions (mm)			Poles	Dimensions (mm)			Poles	Dimensions (mm)		
	A	B	C		A	B	C		A	B	C
02	2.00	6.00	5.00	09	16.00	20.00	19.00	16	30.00	34.00	33.00
03	4.00	8.00	7.00	10	18.00	22.00	21.00	17	32.00	36.00	35.00
04	6.00	10.00	9.00	11	20.00	24.00	23.00	18	34.00	38.00	37.00
05	8.00	12.00	11.00	12	22.00	26.00	25.00	19	36.00	40.00	39.00
06	10.00	14.00	13.00	13	24.00	28.00	27.00	20	38.00	42.00	41.00
07	12.00	16.00	15.00	14	26.00	30.00	29.00				
08	14.00	18.00	17.00	15	28.00	32.00	31.00				

2016WR-XXK-N0SN	Nylon 66 UL 94V-0	Brass	Tin-Plated	2016H
PART NO	Material	Material(Pin)	Finish(Pin)	Mates With SWB Housing

						GENERAL TOLERANCE		 <b>思索连接器有限公司</b> <b>SWB CONNECTORS CO.,LTD</b>				PART NO. 2016WR-XXK-N0SN			
2014/06/18	B	C		Modify the drawing frame format	Wuxiaotao	Jova	.X ±0.30					TITLE 2.00mm Crimp Style Connectors			
2013/09/22	A	B	ECN2013082501	Modify the drawing frame format	Jova	Bob	.XX ±0.20	APPROVAL	CHECK	DRAWN	DATA	UNIT	SCALE	NUMBER	REV
DATE	OLD REV	NEW REV	ECN	DESCRIPTION	CHECK	APPROVAL	PROJECT	Success	Sun Kaibao	Jova	2012/11/22	MM	1 : 1	A-006	C

RoHS  Lead-free

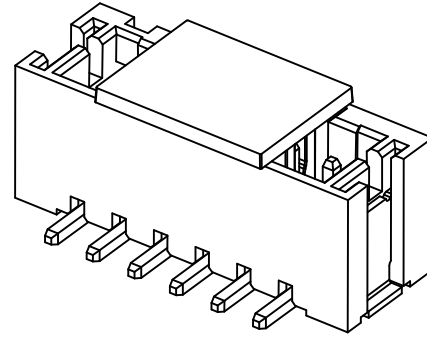
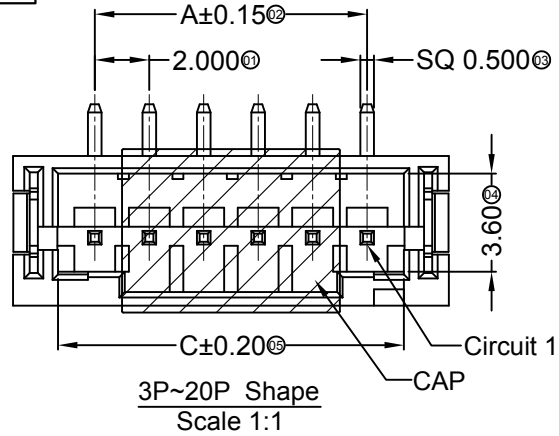

■ Specifications :

- Voltage rating: 100V AC / DC
- Current rating: 2A AC / DC
- Withstanding voltage: 800V AC/minute
- Temperature range: -25°C~+85°C
- Insulation resistance: ≥1000MΩ
- Contact resistance: ≤10mΩ
- After environmental testing: ≤20mΩ

2016 W V S-XX X -XX XXX XX  
① ② ③ ④ ⑤ ⑥ ⑦ ⑧ ⑨

- ① Series No.
- ② Category: W-WAFER
- ③ Welding Board Angle: V-Straight 180°
- ④ Welding Way: S-SMT
- ⑤ Row No.-Pin No.: XX-02P~20P
- ⑥ Plug the Pin & Special No.
- ⑦ Material: LP -LCP 94V-0; 9T -PA9T 94V-0
- ⑧ Plating Category: SW-Bright Tin Plating; V01- Gold Flash
- ⑨ Color : HF-Halogen Free;

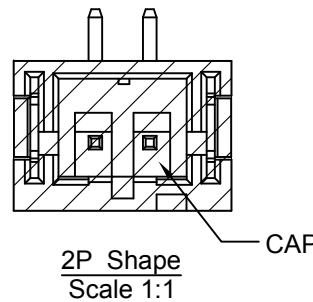
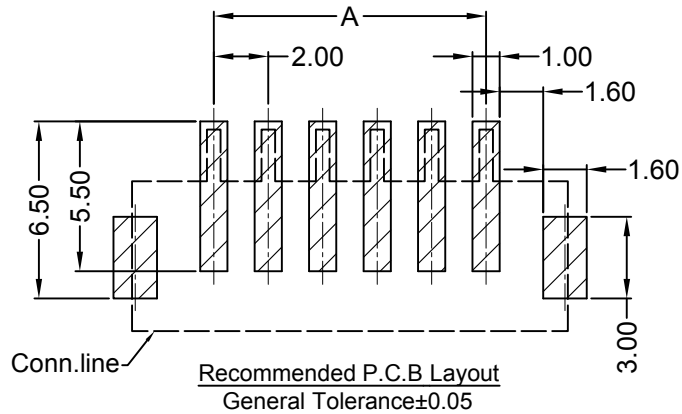
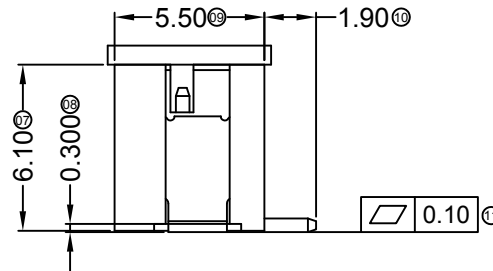
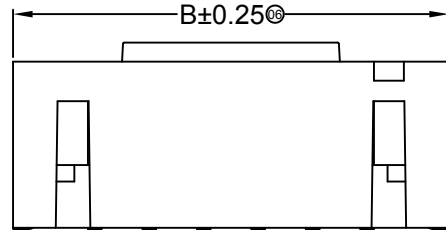

Poles	Dimensions (mm)			Poles	Dimensions (mm)			Poles	Dimensions (mm)		
	A	B	C		A	B	C		A	B	C
02	2.00	8.00	4.70	09	16.00	22.00	18.70	16	30.00	36.00	32.70
03	4.00	10.00	6.70	10	18.00	24.00	20.70	17	32.00	38.00	34.70
04	6.00	12.00	8.70	11	20.00	26.00	22.70	18	34.00	40.00	36.70
05	8.00	14.00	10.70	12	22.00	28.00	24.70	19	36.00	42.00	38.70
06	10.00	16.00	12.70	13	24.00	30.00	26.70	20	38.00	44.00	40.70
07	12.00	18.00	14.70	14	26.00	32.00	28.70				
08	14.00	20.00	16.70	15	28.00	34.00	30.70				

PART NO	Material	Material(Pin)	Finish(Pin)	Material (Solder Tabs)	Finish (Solder Tabs)	Mates With SWB Housing
2016WVS-XX-LPSWHF	LCP UL 94V-0 Halogen Free		Tin-Plated		Tin-Plated	
2016WVS-XX-LPSW	LCP UL 94V-0	Brass	Matte Tin-Plated	Phosphor Bronze	Matte Tin-Plated	2016H
2016WVS-XX-9TV01			Gold-Flash		Gold-Flash	
2016WVS-XX-9TSW	PA9T UL 94V-0		Matte Tin-Plated		Matte Tin-Plated	

DATE	OLD REV	NEW REV	ECN	DESCRIPTION	CHECK	APPROVAL	PROJECT	APPROVAL	CHECK	DRAWN	DATA	UNIT	SCALE	NUMBER	REV
2014/06/23	C	D		Modify the drawing frame format	Wuxiaotao	Jova	GENERAL TOLERANCE					MM	1:1	A-010	D
2014/04/24	B	C		DEL 4,5 DIM	Jova	Bob	.X ±0.30								
							.XX ±0.20								
							.XXX ±0.10								
									Success	Sun Kaibao	Jova				

**SWB** 思索连接器有限公司  
TERMINAL&CONNECTORS SWB CONNECTORS CO.,LTD

PART NO. 2016WVS-XX-XXXXXXX  
TITLE 2.00mm Crimp Style Connectors

RoHS  Lead-free

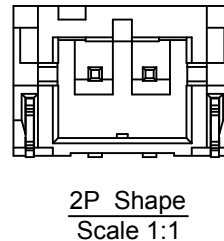
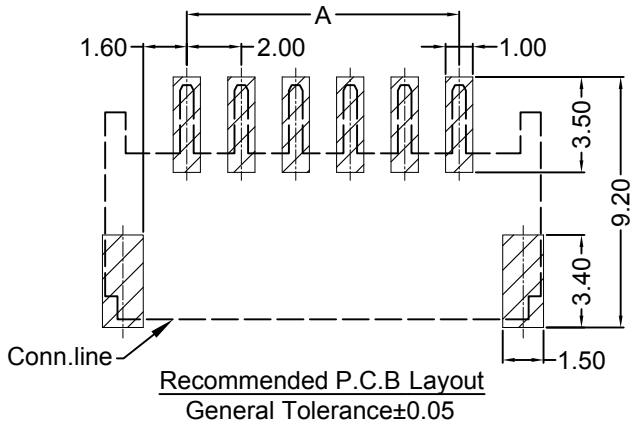
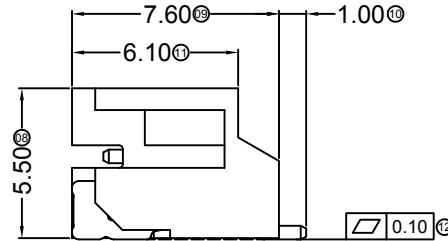
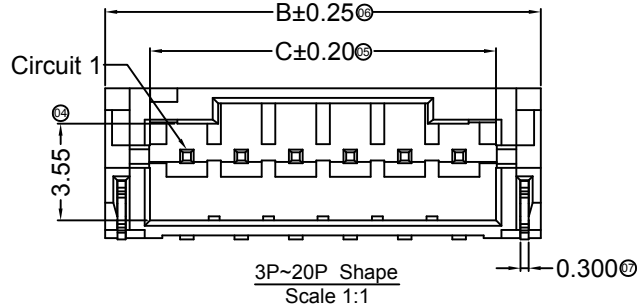
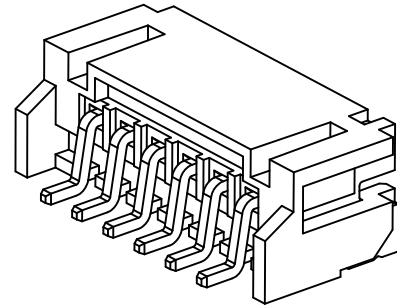
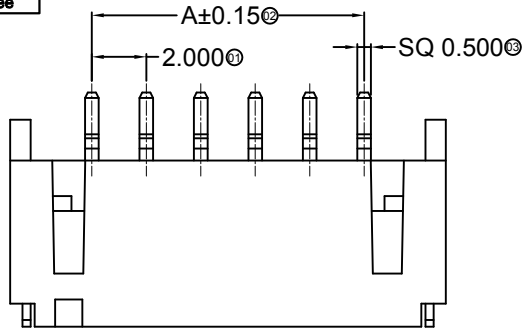

■ Specifications :

- Voltage rating: 100V AC / DC
- Current rating: 2A AC / DC
- Withstanding voltage: 800V AC/minute
- Temperature range: -25°C~+85°C
- Insulation resistance: ≥1000MΩ
- Contact resistance: ≤10mΩ
- After environmental testing: ≤20mΩ

2016 W R S-XX X -XX XXX XX  
① ② ③ ④ ⑤ ⑥ ⑦ ⑧ ⑨

- ① Series No.
- ② Category: W-WAFER
- ③ Welding Board Angle: R-Right Angle 90°
- ④ Welding Way: S-SMT
- ⑤ Row No.-Pin No.: XX-02P~20P
- ⑥ Plug the Pin & Special No.
- ⑦ Material: 9T-PA9T 94V-0 LP-LCP 94V-0
- ⑧ Plating Category: SW-Matte Tin Plating; V15- Gold 15u"
- ⑨ Color : HF-Halogen Free; Blank-Natural Color; Bk-Black

Poles	Dimensions (mm)			Poles	Dimensions (mm)			Poles	Dimensions (mm)		
	A	B	C		A	B	C		A	B	C
02	2.00	8.00	4.70	09	16.00	22.00	18.70	16	30.00	36.00	32.70
03	4.00	10.00	6.70	10	18.00	24.00	20.70	17	32.00	38.00	34.70
04	6.00	12.00	8.70	11	20.00	26.00	22.70	18	34.00	40.00	36.70
05	8.00	14.00	10.70	12	22.00	28.00	24.70	19	36.00	42.00	38.70
06	10.00	16.00	12.70	13	24.00	30.00	26.70	20	38.00	44.00	40.70
07	12.00	18.00	14.70	14	26.00	32.00	28.70				
08	14.00	20.00	16.70	15	28.00	34.00	30.70				

2016WRS-XX-LPSWHF	LCP UL 94V-0 Halogen Free	Brass	Matte Tin-Plated	Brass	Matte Tin-Plated	2016H
2016WRS-XX-LPSW	LCP UL 94V-0		Matte Tin-Plated			
2016WRS-XX-9TV15BK	PA9T UL 94V-0 Black		Gold15u"			
2016WRS-XX-9TSW	PA9T UL 94V-0		Matte Tin-Plated			
PART NO	Material	Material(Pin)	Finish(Pin)	Material (Solder Tabs)	Finish (Solder Tabs)	Mates With SWB Housing

2014/06/17	D	E		Modify the drawing frame format	Jova	Bob	<b>GENERAL TOLERANCE</b> .X ±0.30 .XX ±0.20 .XXX ±0.10	 <b>思索连接器有限公司</b> <b>SWB CONNECTORS CO.,LTD</b>	PART NO. 2016WRS-XX-XXXXXXX						
2014/04/28	C	D		Modify the appearance of the product	Jova	Bob			TITLE 2.00mm Crimp Style Connectors						
2014/04/08	B	C		Modify the drawing frame format	Jova	Bob			APPROVAL	CHECK	DRAWN	DATA			
DATE	OLD REV	NEW REV	ECN	DESCRIPTION	CHECK	APPROVAL	PROJECT	Jova Lau	W.X.T	Wuxiaotao	2014/04/28	UNIT	SCALE	NUMBER	REV
												MM	1:1	A-010	E

RoHS  Lead-free

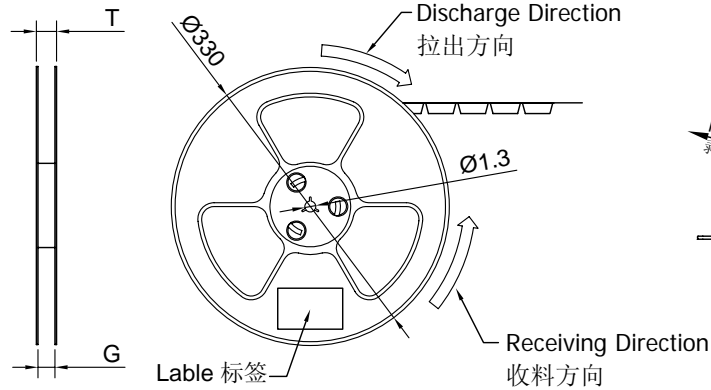
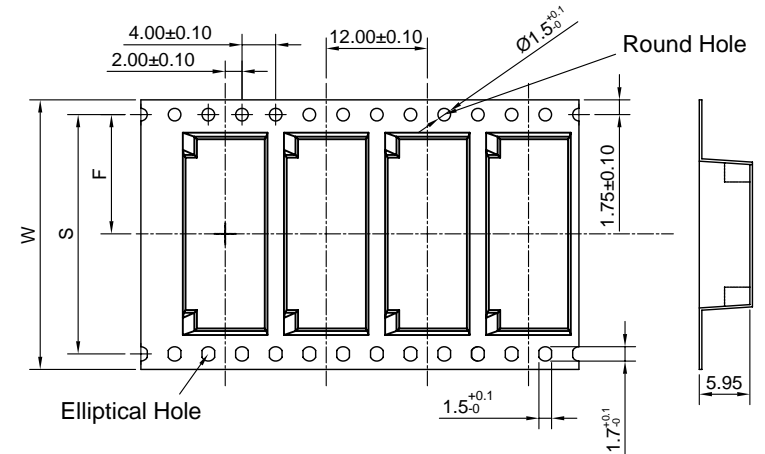
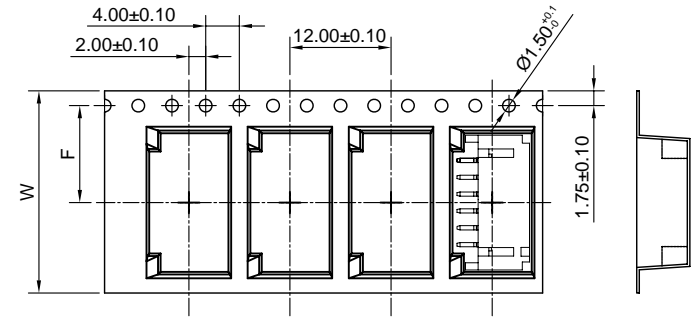
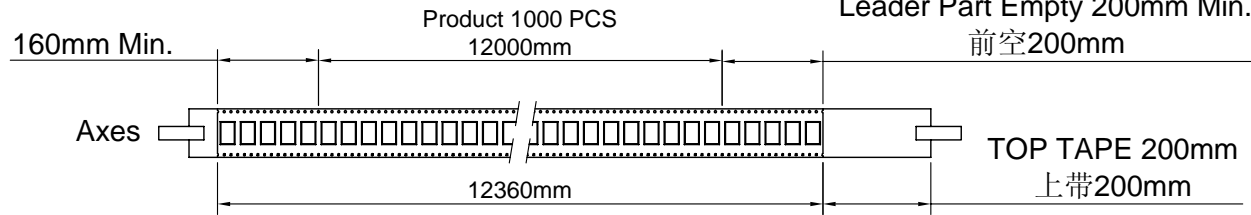

COVER TAPE PEEL STRENGTH: 20~120g  
上带剥离力量: 20~120g  
速度 PEEL SPEED: 300mm/minute

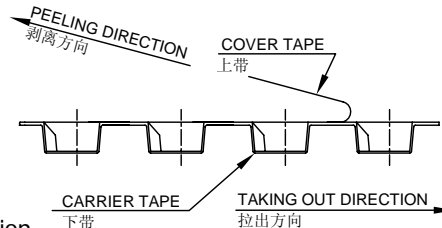

Single hole: None Hole Side  
单孔: 贴无链孔侧  
Double hole: Elliptical Hole Side  
双孔: 贴椭圆孔侧

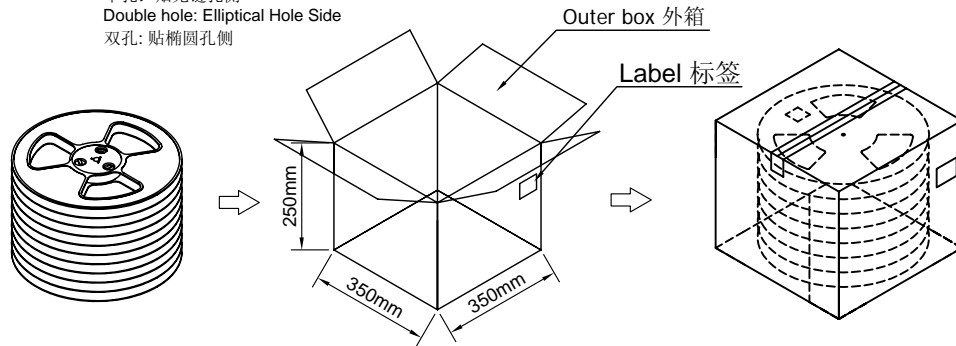

**Note:**

- Carrier Camber Is Within 1mm In 100mm ; 带长100mm内容许弯曲度1mm
- 10 Sprocket Hole Pitch Cumulative Tolerance±0.2MM ; 圆孔十个孔距离累计允许公差为±0.2mm
- Material for PS Black ; 材质为PS材质 黑色
- Thickness=0.40±0.05 ; 材料厚度为0.40±0.05mm

	Pin No.	W	S	F	T	G	REEL /PCS	CARTON /R	CARTON /PCS
ZD2016WRS-XX 2016WRS-XX-XXXX	ZD2016WRS-02	16	/	7.50	20.5	16.4	1000	11	11000
	ZD2016WRS-03								
	ZD2016WRS-04	24	/	11.50	29.5	25.4	1000	8	8000
	ZD2016WRS-05								
	ZD2016WRS-06								
	ZD2016WRS-07	32	28.4	15.50	36.5	32.4	1000	6	6000
	ZD2016WRS-08								
	ZD2016WRS-09								
	ZD2016WRS-10	40	40.4	19.50	44.5	40.4	1000	5	5000
	ZD2016WRS-11								
	ZD2016WRS-12								
	ZD2016WRS-13	48	40.4	24.50	52.5	48.4	1000	4	4000
	ZD2016WRS-14								
	ZD2016WRS-15								
	ZD2016WRS-16	56	52.4	28.50	60.5	56.4	1000	3	3000

GENERAL TOLERANCE

.X ±0.30  
.XX ±0.20  
.XXX ±0.10



思索连接器有限公司  
SWB CONNECTORS CO.,LTD

PART NO. PPN: 2016WRS-XX-XXXX  
CPN: ZD2016WRS-XX

TITLE  
2.00mm Connectors 90° Package

APPROVAL CHECK DRAWN DATA

Allen 2013/12/09

UNIT SCALE NUMBER REV  
MM 1:1 A-106 B

PROJECT

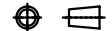

DATE OLD REV NEW REV ECN DESCRIPTION CHECK APPROVAL

RoHS Lead-free

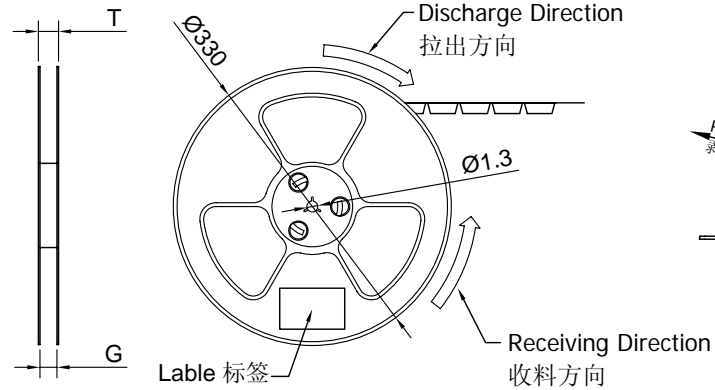
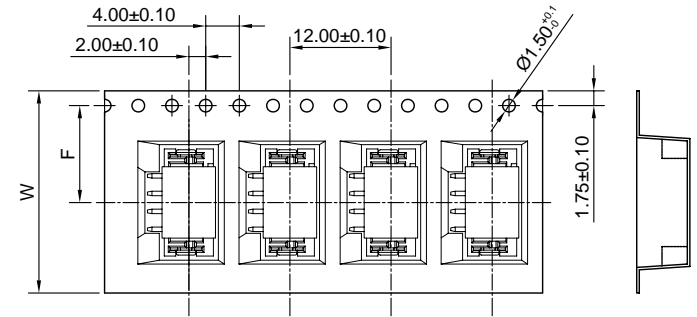
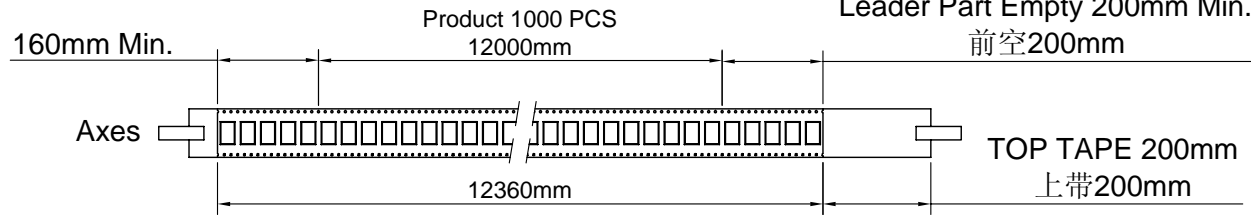

COVER TAPE PEEL STRENGTH: 20~120g  
 上带剥离力量: 20~120g  
 速度 PEEL SPEED: 300mm/minute

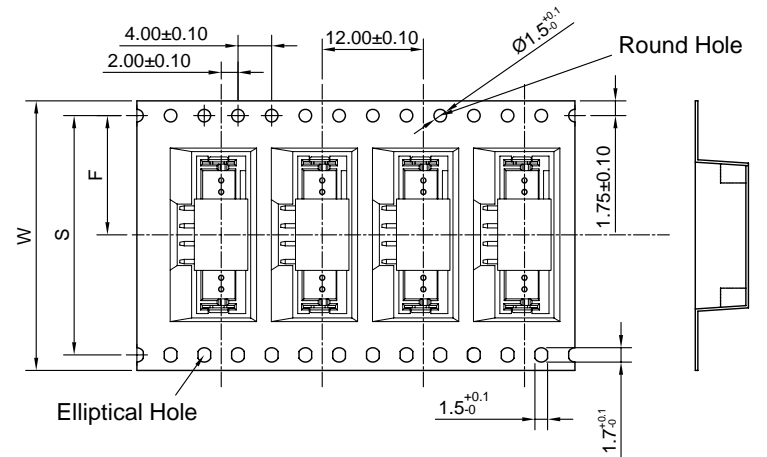
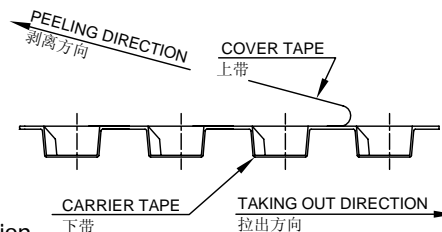

Single hole: None Hole Side  
 单孔: 贴无链孔侧  
 Double hole: Elliptical Hole Side  
 双孔: 贴椭圆孔侧

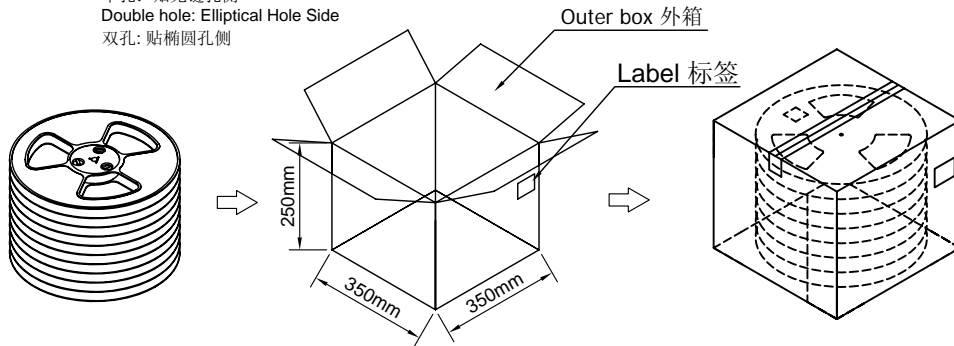

**Note:**

- Carrier Camber Is Within 1mm In 100mm ; 带长100mm内容许弯曲度1mm
- 10 Sprocket Hole Pitch Cumulative Tolerance±0.2MM ; 圆孔十个孔距离累计允许公差为±0.2mm
- Material for PS ; 材质为PS材质
- Thickness=0.40±0.05 ; 材料厚度为0.40±0.05mm

Pin No.	W	S	F	T	G	REEL /PCS	CARTON /R	CARTON /PCS
ZD2016WVS-02	16	/	7.50	20.5	16.4	1000	11	11000
ZD2016WVS-03								
ZD2016WVS-04	24	/	11.50	29.5	25.4	1000	8	8000
ZD2016WVS-05								
ZD2016WVS-06								
ZD2016WVS-07	32	28.4	15.50	36.5	32.4	1000	6	6000
ZD2016WVS-08								
ZD2016WVS-09								
ZD2016WVS-10	40	40.4	19.50	44.5	40.4	1000	5	5000
ZD2016WVS-11								
ZD2016WVS-12								
ZD2016WVS-13	48	40.4	24.50	52.5	48.4	1000	4	4000
ZD2016WVS-14								
ZD2016WVS-15	56	52.4	28.50	60.5	56.4	1000	3	3000
ZD2016WVS-16								

GENERAL TOLERANCE

.X ±0.30  
 .XX ±0.20  
 .XXX ±0.10



思索连接器有限公司  
 SWB CONNECTORS CO.,LTD

PART NO. PPN: 2016WVS-XX-XXXX  
 CPN: ZD2016WVS-XX

TITLE  
 2.00mm Connectors 180° Package

APPROVAL CHECK DRAWN DATA

PROJECT

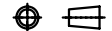

Allen 2013/12/09

UNIT SCALE NUMBER REV  
 MM 1:1 A-106 B

DATE OLD REV NEW REV ECN DESCRIPTION CHECK APPROVAL