

■ Specifications :

- Voltage rating: 250V AC / DC
- Current rating: 2A AC / DC
- Withstanding voltage: 1000V AC/minute
- Temperature range: -25°C~+85°C
- Insulation resistance: ≥1000MΩ
- Contact resistance: ≤20mΩ
- After environmental testing : ≤30mΩ

2012 T X-P SN X-X

① ② ③ ④ ⑤ ⑥ ⑦

- ① Series No.
- ② Category: T-Terminal
- ③ Appearance type: Blank-Ordinary
- ④ Material: P-Phosphor bronze
B-Brass
- ⑤ Plating Style: G**-Gold Plated Contact
V**- All Gold-Plated
01-Gold Flash 02-2u" 03-3u"
05-5u" 10-10u" 15-15u"
SN-Bright Tin Plating (70-120u")
SN1-Bright Tin Plating (120u" Min).
0-No Plating Material
SW- Fog Tin Plating
- ⑥ Plating Method : Blank-Stamping before Plating
B-Plating before stamping
- ⑦ Mold No./Mark/Special No.

2012T-PSNB	Phosphor Bronze	AWG#24-30	1.40mm(Max)	Plating Before Stamping:10~30u" Ni;40~60u"Sn	2012H	10,000Pcs
2012T-PSN				Stamping Before Plating:30~50u" Ni;70~120u"Sn		
PART NO	Material	Wire Range	Insulation O.D.	Finish	Used In SWB Housing	Q'ty/Reel

							 思索连接器有限公司 SWB Connectors CO.,LTD				PART NO. 2012T-PSNX			
2014/04/15	C	D	/	Shape modification	Jova		APPROVAL				TITLE 2.00 mm Crimp Style Connector			
2014/04/14	B	C	/	Shape modification	Jova		CHECK				NUMBER A-003			
DATE	OLD REV	NEW REV	ECN	DESCRIPTION	CHECK	APPROVAL	DRAWN Wuxiaotao				REV D			
							PROJECT				2014/04/14			

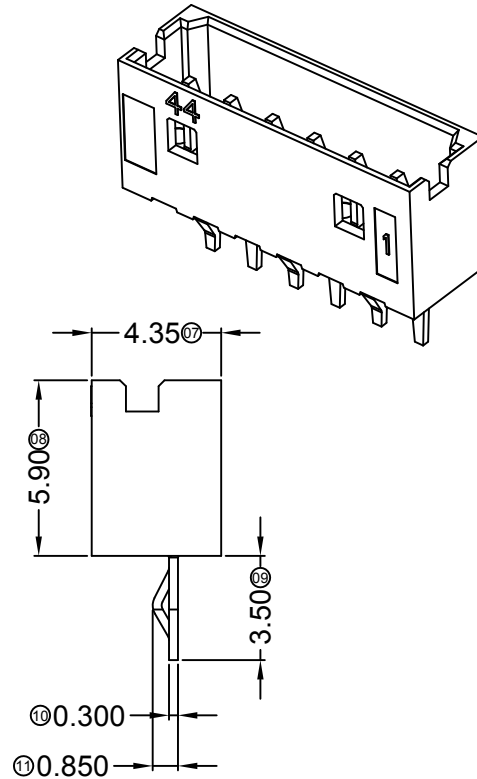
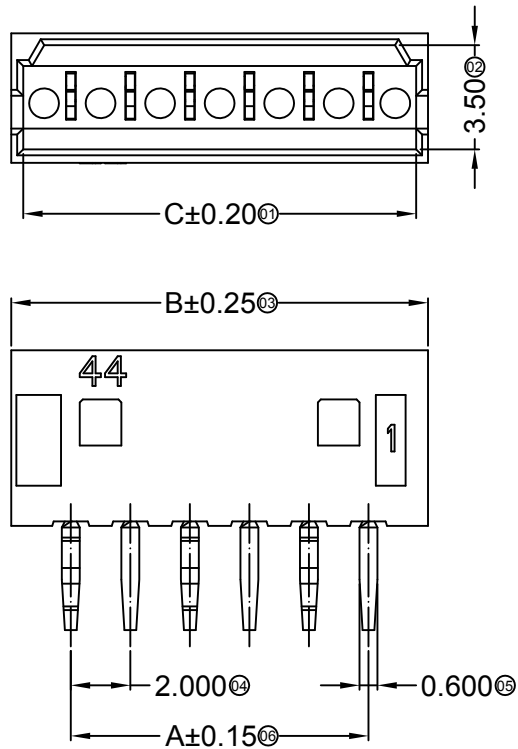

■ Specifications :

- Voltage rating: 250V AC / DC
- Current rating: 2A AC / DC
- Withstanding voltage: 1000V AC/minute
- Temperature range: -25°C~+85°C
- Insulation resistance: ≥1000MΩ
- Contact resistance: ≤20mΩ
- After environmental testing: ≤30mΩ

2012 W V X-XX X-N0 SN XX
 ① ② ③ ④ ⑤ ⑥ ⑦ ⑧ ⑨

- ① Series No.
- ② Category: W-WAFER
- ③ Welding Board Angle: V-Straight 180°
- ④ Welding Way: Blank-DIP
- ⑤ Row No.-Pin No.: XX-02P~15P
- ⑥ Plug the Pin & Special No.:
- ⑦ Material: N0 -PA66 UL 94V-0
- ⑧ Plating Category: SN-Bright Tin Plating
- ⑨ Color : Blank-Natural Color

Poles	Dimensions (mm)			Poles	Dimensions (mm)		
	A	B	C		A	B	C
02	2.00	6.00	5.20	09	16.00	20.00	19.20
03	4.00	8.00	7.20	10	18.00	22.00	21.20
04	6.00	10.00	9.20	11	20.00	24.00	23.20
05	8.00	12.00	11.20	12	22.00	26.00	25.20
06	10.00	14.00	13.20	13	24.00	28.00	27.20
07	12.00	16.00	15.20	14	26.00	30.00	29.20
08	14.00	18.00	17.20	15	28.00	32.00	31.20

2012WV-XX-N0SN	PA 66 UL 94V-0	Brass	Tin-Plated	2012H
PART NO	Material	Material(Pin)	Finish(Pin)	Mates With SWB Housing

Recommended P.C.B Layout
 General Tolerance±0.05

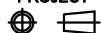
							 思索连接器有限公司 SWB CONNECTORS CO.,LTD				PART NO. 2012WV-XX-N0SN TITLE 2.00mm Crimp Style Connector				
2014/10/21	C	D	/	Space of a Whole page Changes	W.X.T	Jova	GENERAL TOLERANCE	APPROVAL	CHECK	DRAWN	DATA	UNIT	SCALE	NUMBER	REV
2013/08/23	B	C	/	Modify drawing frame format	Jova		.X ±0.30	Success	Sun Kaibao	Jova	2007/05/03	MM	1 : 1	A-007	D
DATE	OLD REV	NEW REV	ECN	DESCRIPTION	CHECK	APPROVAL	.XX ±0.20	PROJECT							
							.XXX ±0.10								

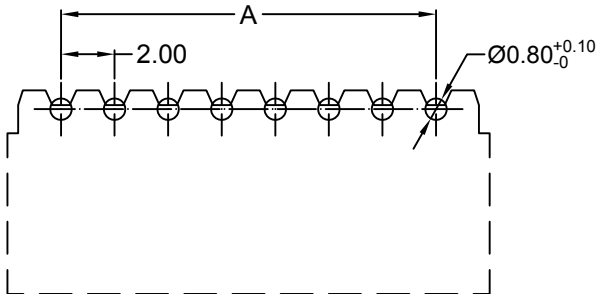
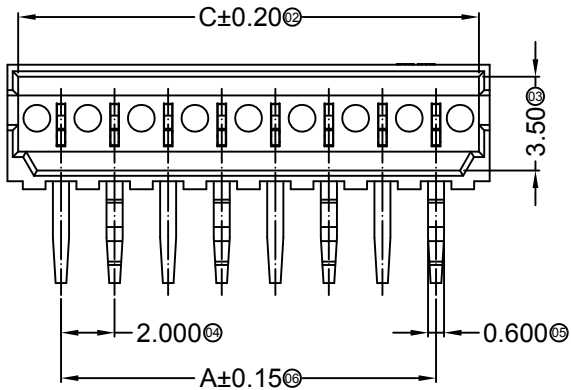

Conn.line Recommended P.C.B Layout
General Tolerance±0.05

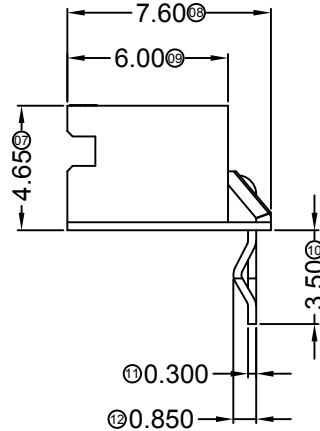
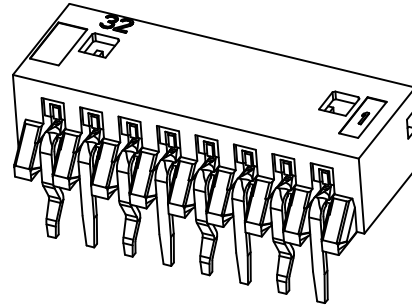

■ Specifications :



- Voltage rating: 250V AC / DC
- Current rating: 2A AC / DC
- Withstanding voltage: 1000V AC/minute
- Temperature range: -25°C~+85°C
- Insulation resistance: ≥1000MΩ
- Contact resistance: ≤20mΩ
- After environmental testing: ≤30mΩ

2012 W R X-XX X-N0 SN XX
① ② ③ ④ ⑤ ⑥ ⑦ ⑧

- ① Series No.
- ② Category: W-WAFER
- ③ Welding Board Angle: R-Right Angle 90°
- ④ Welding Way: Blank-DIP
- ⑤ Row No.-Pin No.: XX-02P~15P
- ⑥ Plug the Pin & Special No.:
- ⑦ Material: N0 -PA66 UL 94V-0
- ⑧ Plating Category: SN-Bright Tin Plating
- ⑨ Color : Blank-Natural Color

Poles	Dimensions (mm)			Poles	Dimensions (mm)		
	A	B	C		A	B	C
02	2.00	6.00	5.20	09	16.00	20.00	19.20
03	4.00	8.00	7.20	10	18.00	22.00	21.20
04	6.00	10.00	9.20	11	20.00	24.00	23.20
05	8.00	12.00	11.20	12	22.00	26.00	25.20
06	10.00	14.00	13.20	13	24.00	28.00	27.20
07	12.00	16.00	15.20	14	26.00	30.00	29.20
08	14.00	18.00	17.20	15	28.00	32.00	31.20

2012WR-XX-N0SN	PA 66 UL 94V-0	Brass	Tin-Plated	2012H
PART NO	Material	Material(Pin)	Finish(Pin)	Mates With SWB Housing

								 思索连接器有限公司 SWB CONNECTORS CO.,LTD		PART NO. 2012WR-XX-N0SN TITLE 2.00mm Crimp Style Connector			
2014/10/21	C	D	/	Space of a Whole page Changes	W.X.T	Jova	GENERAL TOLERANCE .X ±0.30 .XX ±0.20 .XXX ±0.10		APPROVAL	CHECK	DRAWN	DATA	
2013/08/23	B	C	/	Modify drawing frame format	Jova		PROJECT		Success	Sun Kaibao	Jova	2007/05/03	
DATE	OLD REV	NEW REV	ECN	DESCRIPTION	CHECK	APPROVAL			UNIT	SCALE	NUMBER	REV	
									MM	1 : 1	A-106	D	