

RoHS  Lead-free

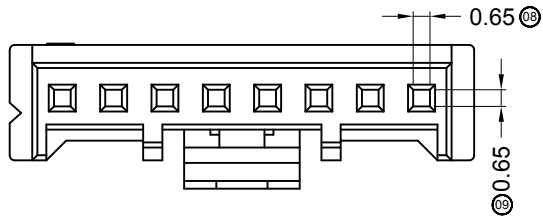
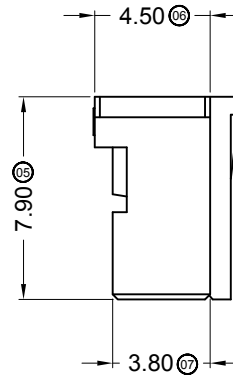
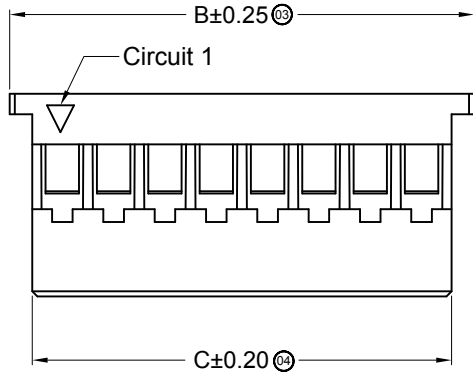
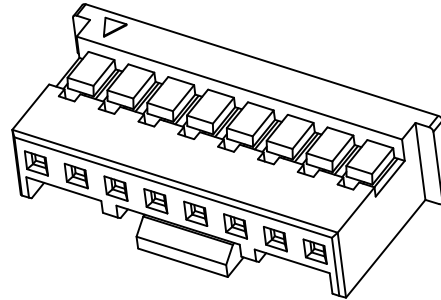
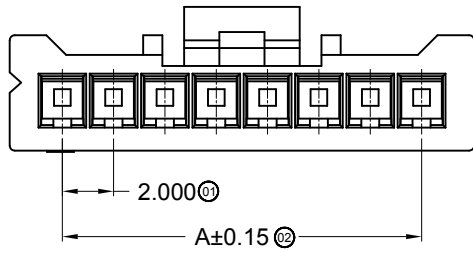

■ Specifications :

- Voltage rating: 250V AC / DC
- Current rating: 3A AC / DC
- Withstanding voltage: 800V AC/minute
- Temperature range: -25°C~+85°C
- Insulation resistance: ≥1000MΩ
- Contact resistance: ≤10mΩ
- After environmental testing: ≤20mΩ

2000 H X-XX X-N0 HF

① ② ③ ④ ⑤ ⑥ ⑦

- ① Series No.
- ② Category: H-HSG
- ③ Appearance type: Blank-Ordinary
- ④ Row No.-Pin No.: XX-02P~16P
- ⑤ Plug the Pin & Special No.: Blank-Ordinary
- ⑥ Material : N0-PA66 94V-0
- ⑦ HF-Halogen Free

Poles	Dimensions (mm)			Poles	Dimensions (mm)		
	A	B	C		A	B	C
02	2.00	6.10	4.34	10	18.00	22.10	20.34
03	4.00	8.10	6.34	11	20.00	24.10	22.34
04	6.00	10.10	8.34	12	22.00	26.10	24.34
05	8.00	12.10	10.34	13	24.00	28.10	26.34
06	10.00	14.10	12.34	14	26.00	30.10	28.34
07	12.00	16.10	14.34	15	28.00	32.10	30.34
08	14.00	18.10	16.34	16	30.00	34.10	32.34
09	16.00	20.10	18.34				

2000H-XX-N0HF	PA66 UL 94V-0 Halogen Free	2000T	2000W
2000H-XX-N0	Nylon 66 94V-0		
PART N0	Material	Suitable SWB Terminal	Suitable SWB Wafer

2014/04/30	E	F		Adjustment drawing	Jova		GENERAL TOLERANCE .X ±0.30 .XX ±0.20 .XXX ±0.10	 思索连接器有限公司 SWB CONNECTORS CO.,LTD	PART NO. 2000H-XX-N0HF						
2013/09/11	D	E	ECN2013091101	Change the No. 3 ball location	Jova				TITLE 2.00mm Crimp Style Connector						
2013/08/23	C	D		Modify drawing frame format	Jova				APPROVAL	CHECK	DRAWN	DATA			
DATE	OLD REV	NEW REV	ECN	DESCRIPTION	CHECK	APPROVAL	PROJECT	Bob Sun	Jova Lau	Wuxiaotao	2014/05/04	UNIT MM	SCALE 1:1	NUMBER A-089	REV F

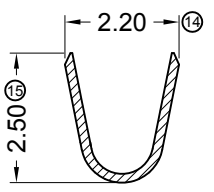
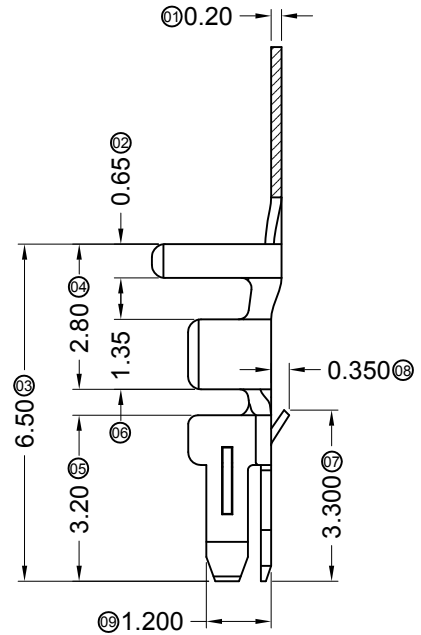
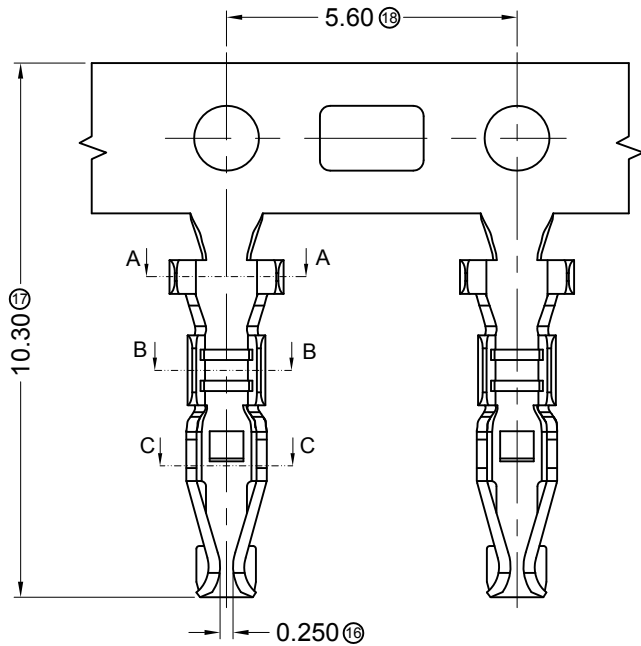

SECTION: A-A
SCALE: 1:1

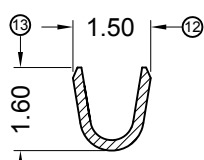

SECTION: B-B
SCALE: 1:1

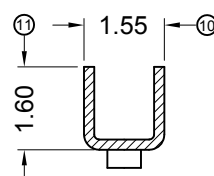

SECTION: C-C
SCALE: 1:1

■ Specifications :

- Voltage rating: 250V AC / DC
- Current rating: 3A AC / DC
- Withstanding voltage: 800V AC/minute
- Temperature range: -25°C~+85°C
- Insulation resistance: ≥1000MΩ
- Contact resistance: ≤10mΩ
- After environmental testing: ≤20mΩ

2000 T X-P XX X-X
① ② ③ ④ ⑤ ⑥ ⑦

- ① Series No.
- ② Category: T-Terminal
- ③ Appearance type: Blank-Ordinary
- ④ Material: P-Phosphor bronze
- ⑤ Plating Style: G03-Contact Gold 3u"
SN-Bright Tin Plating
- ⑥ Plating Method : B-Plating before stamping
- ⑦ Mold No./Mark/Special No.

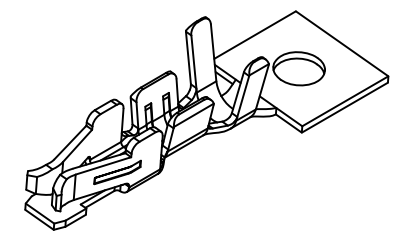

2000T-PG03				Stamping Before Plating:30u" Ni;Contact Gold:3u"	2000H
2000T-PSNB	Phosphor Bronze	AWG#22-28	1.50mm(Max)	Plating Before Stamping:10u" Ni;40u"Sn	
2000T-PSN				Stamping Before Plating:30u" Ni;70u"Sn	
PART NO	Material	Wire Range	Insulation O.D.	Finish	Used In SWB Housing

						GENERAL TOLERANCE .X ±0.30 .XX ±0.20 .XXX ±0.10				SWB 思索连接器有限公司 TERMINAL&CONNECTORS SWB CONNECTORS CO.,LTD				PART NO. 2000T-PXX TITLE 2.00mm Crimp Style Connectors			
2014/05/05	B	C		Modify the drawing frame format	sylvania												
2013/08/23	A	B		Modify the drawing frame format	Jova												
DATE	OLD REV	NEW REV	ECN	DESCRIPTION	CHECK	APPROVAL	PROJECT	APPROVAL	CHECK	DRAWN	DATA	UNIT	SCALE	NUMBER	REV		
							⊕	Joav Lau	Wu Xiao Tao	Xiaowx	2014/05/05	MM	1:1	A-106	C		

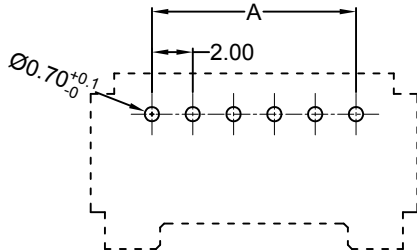
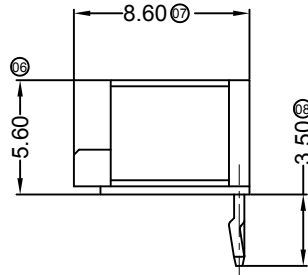
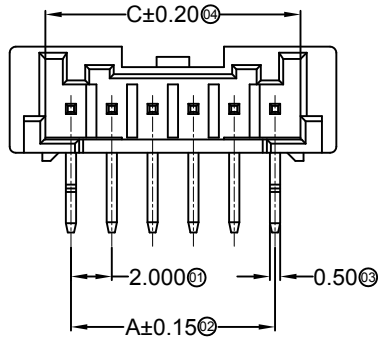
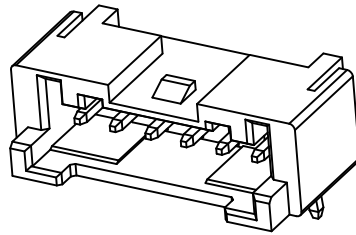
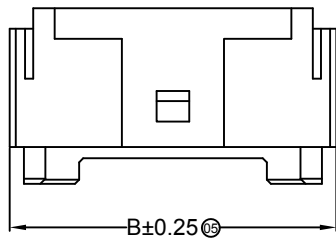

Recommended P.C.B Layout
 General Tolerance ± 0.05

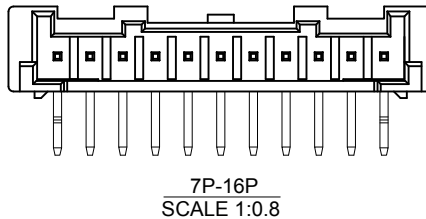
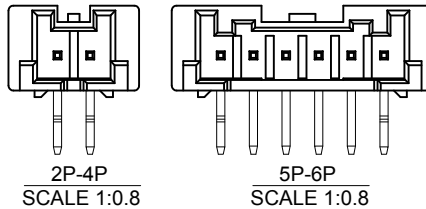

■ Specifications :

- Voltage rating: 250V AC / DC
- Current rating: 3A AC / DC
- Withstanding voltage: 800V AC/minute
- Temperature range: $-25^{\circ}\text{C} \sim +85^{\circ}\text{C}$
- Insulation resistance: $\geq 1000\text{M}\Omega$
- Contact resistance: $\leq 10\text{m}\Omega$
- After environmental testing: $\leq 20\text{m}\Omega$

2000 W R X-XX X -9T SN XX
 ① ② ③ ④ ⑤ ⑥ ⑦ ⑧ ⑨

- ① Series No.
- ② Category: W-WAFER
- ③ Welding Board Angle: R-Right Angle 90°
- ④ Welding Way: Blank-DIP
- ⑤ Row No.-Pin No.: XX-02P~16P
- ⑥ Plug the Pin & Special No.
- ⑦ Material: 9T -PA9T 94V-0
- ⑧ Plating Category: SN-Bright Tin Plating
- ⑨ Color : Blank-Natural Color

Poles	Dimensions (mm)			Poles	Dimensions (mm)		
	A	B	C		A	B	C
02	2.00	8.00	4.50	10	18.00	24.00	20.50
03	4.00	10.00	6.50	11	20.00	26.00	22.50
04	6.00	12.00	8.50	12	22.00	28.00	24.50
05	8.00	14.00	10.50	13	24.00	30.00	26.50
06	10.00	16.00	12.50	14	26.00	32.00	28.50
07	12.00	18.00	14.50	15	28.00	34.00	30.50
08	14.00	20.00	16.50	16	30.00	36.00	32.50
09	16.00	22.00	18.50				

2000WR-XX-9TSN	PA9T UL 94V-0	Brass	Tin-Plated	2000H
PART NO	Material	Material(Pin)	Finish(Pin)	Mates With SWB Housing

DATE	OLD REV	NEW REV	ECN	DESCRIPTION	CHECK	APPROVAL	PROJECT	APPROVAL	CHECK	DRAWN	DATA	UNIT	SCALE	NUMBER	REV
2014/05/05	D	E		Space of a Whole page Changes	Jova	Bob	GENERAL TOLERANCE					MM	1:1	A-106	E
2013/08/23	C	D		Modify drawing frame format	Jova	Bob	.X ± 0.30								
							.XX ± 0.20								
							.XXX ± 0.10								

SWB 思索连接器有限公司
 TERMINAL CONNECTORS SWB CONNECTORS CO.,LTD

PART NO. 2000WR-XX-9TSN

TITLE 2.00mm Crimp Style Connector

APPROVAL Bob Sun
 CHECK Jova Lau
 DRAWN Wuxiaotao
 DATA 2014/05/05

RoHS  Lead-free

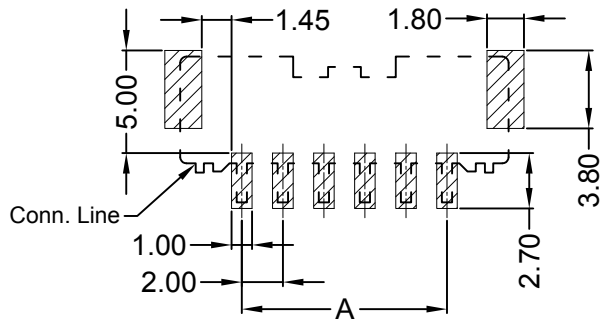
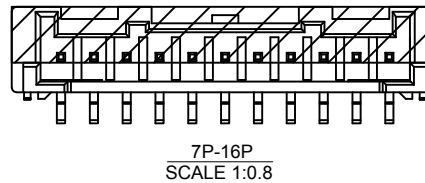
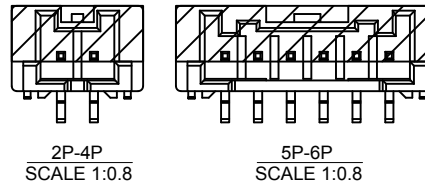
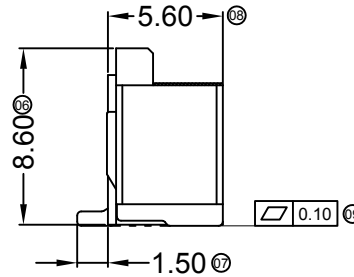
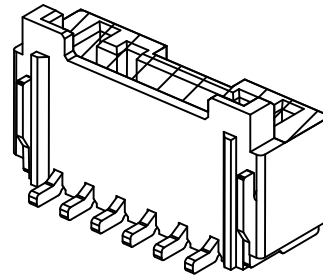
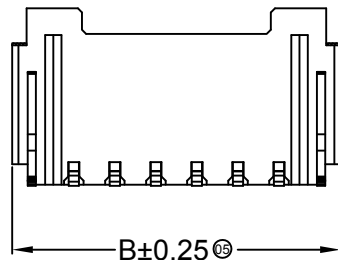
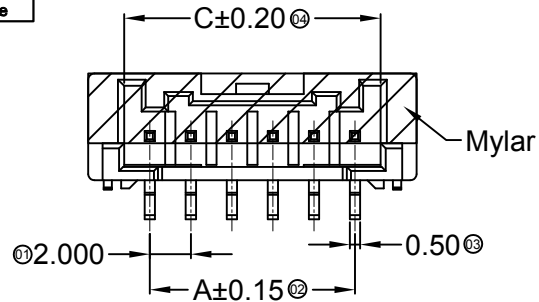

Recommended P.C.B Layout
General Tolerance±0.05

■ Specifications :

- Voltage rating: 250V AC / DC
- Current rating: 3A AC / DC
- Withstanding voltage: 800V AC/minute
- Temperature range: -25°C~+85°C
- Insulation resistance: ≥1000MΩ
- Contact resistance: ≤10mΩ
- After environmental testing: ≤20mΩ

2000 W V S-XX X -9T XX XX
① ② ③ ④ ⑤ ⑥ ⑦ ⑧ ⑨

- ① Series No.
- ② Category: W-WAFER
- ③ Welding Board Angle: V-Straight 180°
- ④ Welding Way: S-SMT
- ⑤ Row No.-Pin No.: XX-02P~16P
- ⑥ Plug the Pin & Special No.
- ⑦ Material: 9T -PA9T 94V-0
- ⑧ Plating Category: SN-Bright Tin ; SW-Matte Tin
- ⑨ Color : Blank-Natural Color

Poles	Dimensions (mm)			Poles	Dimensions (mm)		
	A	B	C		A	B	C
02	2.00	8.00	4.50	10	18.00	24.00	20.50
03	4.00	10.00	6.50	11	20.00	26.00	22.50
04	6.00	12.00	8.50	12	22.00	28.00	24.50
05	8.00	14.00	10.50	13	24.00	30.00	26.50
06	10.00	16.00	12.50	14	26.00	32.00	28.50
07	12.00	18.00	14.50	15	28.00	34.00	30.50
08	14.00	20.00	16.50	16	30.00	36.00	32.50
09	16.00	22.00	18.50				

2000WVS-XX-9TSW	PA9T UL 94V-0	Brass	Matte Tin	Brass	Matte Tin	2000H
2000WVS-XX-9TSN			Tin-Plated		Tin Plating	
PART NO	Material	Material(Pin)	Finish(Pin)	Material (Solder Tabs)	Finish (Solder Tabs)	Mates With SWB Housing

						GENERAL TOLERANCE		 思索连接器有限公司 SWB CONNECTORS CO.,LTD				PART NO. 2000WVS-XX-9TXX									
2014/05/05		D	E	Space of a Whole page Changes		Jova	Bob	.X	±0.30	APPROVAL		CHECK		DRAWN		DATA		TITLE 2.00mm Crimp Style Connector			
2013/08/23		C	D	Modify drawing frame format		Jova	Bob	.XX	±0.20	Bob Sun		Jova Lau		Wuxiaotao		2014/05/06		UNIT	SCALE	NUMBER	REV
DATE	OLD REV	NEW REV	ECN	DESCRIPTION	CHECK	APPROVAL	PROJECT											MM	1:1	A-010	E

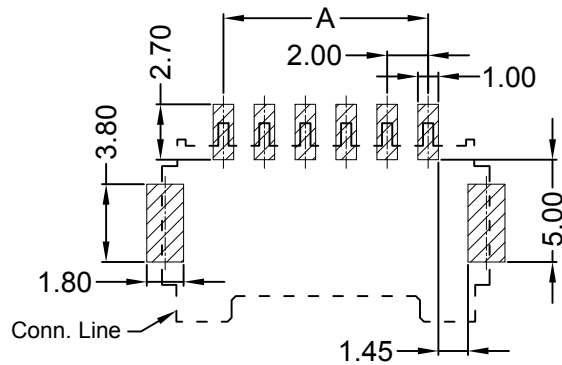
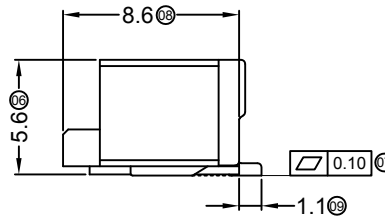
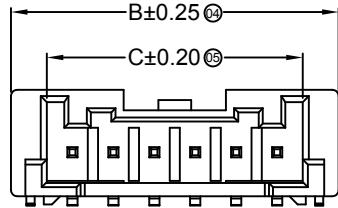
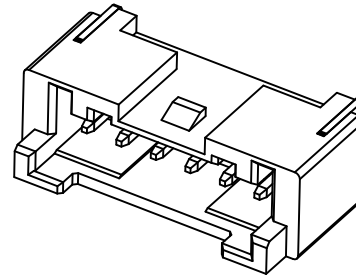
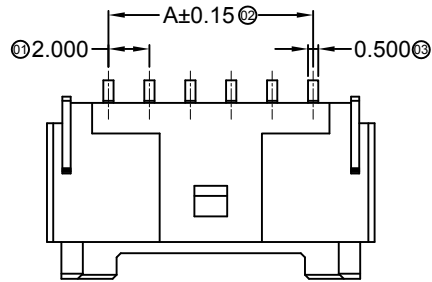

Recommended P.C.B Layout
General Tolerance±0.05

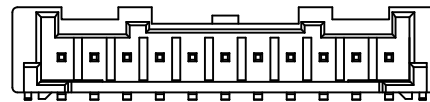
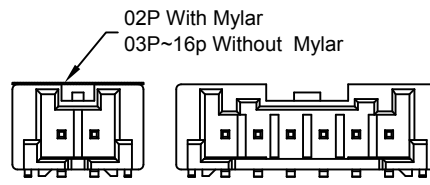

7P-16P
SCALE 1:0.8

■ Specifications :

- Voltage rating: 250V AC / DC
- Current rating: 3A AC / DC
- Withstanding voltage: 800V AC/minute
- Temperature range: -25°C~+85°C
- Insulation resistance: ≥1000MΩ
- Contact resistance: ≤10mΩ
- After environmental testing: ≤20mΩ

2000 W R S-XX X -9T XX XX
① ② ③ ④ ⑤ ⑥ ⑦ ⑧ ⑨

- ① Series No.
- ② Category: W-WAFER
- ③ Welding Board Angle: R-Right Angle 90°
- ④ Welding Way: S-SMT
- ⑤ Row No.-Pin No.: XX-02P~16P
- ⑥ Plug the Pin & Special No.
- ⑦ Material: 9T -PA9T 94V-0
- ⑧ Plating Category: SN-Bright Tin Plating ;SW- Matte Tin
- ⑨ Color : Blank-Natural Color

Poles	Dimensions (mm)			Poles	Dimensions (mm)		
	A	B	C		A	B	C
02	2.00	8.00	4.50	10	18.00	24.00	20.50
03	4.00	10.00	6.50	11	20.00	26.00	22.50
04	6.00	12.00	8.50	12	22.00	28.00	24.50
05	8.00	14.00	10.50	13	24.00	30.00	26.50
06	10.00	16.00	12.50	14	26.00	32.00	28.50
07	12.00	18.00	14.50	15	28.00	34.00	30.50
08	14.00	20.00	16.50	16	30.00	36.00	32.50
09	16.00	22.00	18.50				

2000WRS-XX-9TSW	PA9T UL 94V-0	Brass	Matte Tin	Brass	Matte Tin	2000H
2000WRS-XX-9TSN			Tin Plating		Tin Plating	
PART NO	Material	Material(Pin)	Finish(Pin)	Material (Solder Tabs)	Finish (Solder Tabs)	Mates With SWB Housing

						GENERAL TOLERANCE		 思索连接器有限公司 SWB CONNECTORS CO.,LTD				PART NO. 2000WRS-XX-9TXX			
2014/05/05	D	E	/	Space of a Whole page Changes	Jova	Bob	.X ±0.30					TITLE 2.00mm Crimp Style Connector			
2013/08/23	C	D	/	Modify drawing frame format	Jova	Bob	.XX ±0.20	APPROVAL	CHECK	DRAWN	DATA				
DATE	OLD REV	NEW REV	ECN	DESCRIPTION	CHECK	APPROVAL	PROJECT	Bob Sun	Jova Lau	Wuxiaotao	2014/05/05	UNIT MM	SCALE 1:1	NUMBER A-010	REV E

RoHS Lead-free

Product 500PCS(10~12P)
Product 1000 PCS (02~09P)
8000mm (10~12P)
16000mm (02~09P)

Leader Part Empty 200mm Min.
前空200mm

160mm Min.

Axes

8360mm (10~12P) / 16360mm (02~09P)

TOP TAPE 200mm
上带200mm

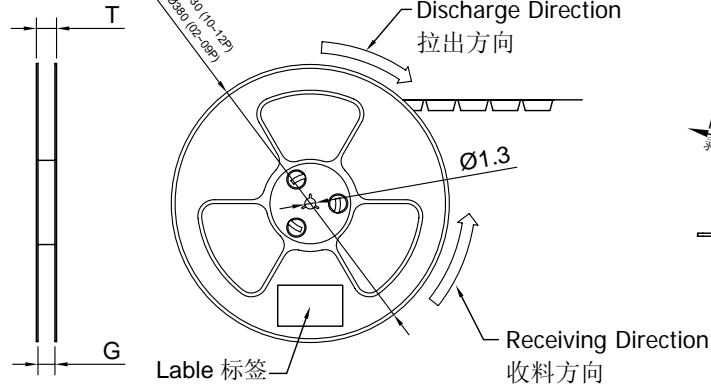

COVER TAPE PEEL STRENGTH:20~120g
上带剥离力量: 20~120g

速度 PEEL SPEED:300mm/minute

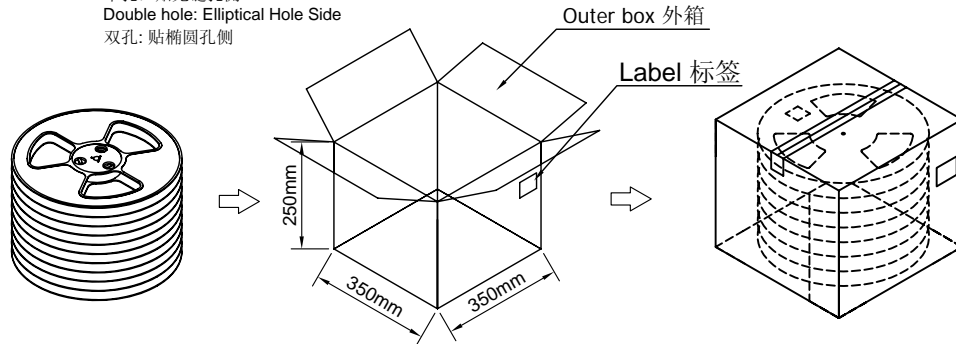
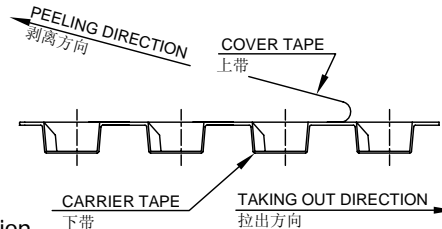

Note:

1. Carrier Camber Is Within 1mm In 100mm ; 带长100mm内容许弯曲度1mm
2. 10 Sprocket Hole Pitch Cumulative Tolerance±0.2MM ; 圆孔十个孔距离累计允许公差为±0.2mm
3. Material for PS ; 材质为PS材质
4. Thickness=0.30±0.05 ; 材料厚度为0.30±0.05mm

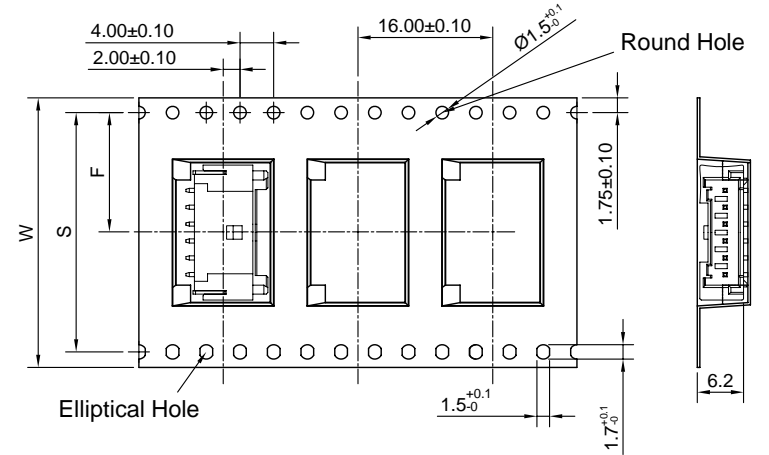
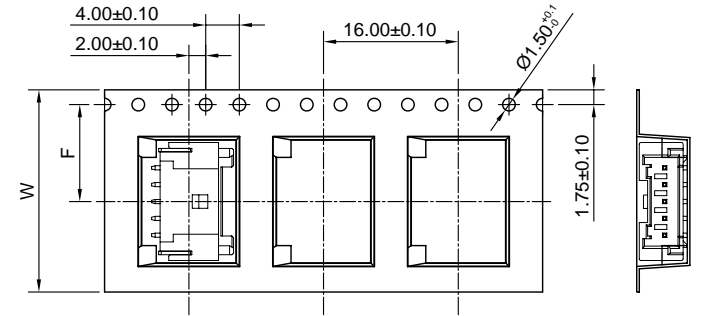

	Pin No.	W	S	F	T	G	REEL /PCS	CARTON /R	CARTON /PCS
ZD2000WRS-XX 2000WRS-XX-XXXX	ZD2000WRS-02	24	/	11.50	27.0	25.5	1000	8	8000
	ZD2000WRS-03								
	ZD2000WRS-04								
	ZD2000WRS-05								
	ZD2000WRS-06								
	ZD2000WRS-07	32	28.4	14.20	35.0	33.5	1000	6	6000
	ZD2000WRS-08								
	ZD2000WRS-09								
	ZD2000WRS-10	44	40.4	20.2	47.0	45.5	500	5	2500
	ZD2000WRS-11								
	ZD2000WRS-12								

GENERAL TOLERANCE

.X ±0.30
.XX ±0.20
.XXX ±0.10



思索连接器有限公司
SWB CONNECTORS CO.,LTD

PART NO. PPN: 2000WRS-XXX-XXXX
CPN: ZD2000WRS-XX

TITLE
2.00mm Connectors 90° Package

APPROVAL CHECK DRAWN DATA

Allen 2013/12/09

UNIT SCALE NUMBER REV
MM 1:1 A-106 B

DATE OLD REV NEW REV ECN DESCRIPTION CHECK APPROVAL



PROJECT

RoHS Lead-free

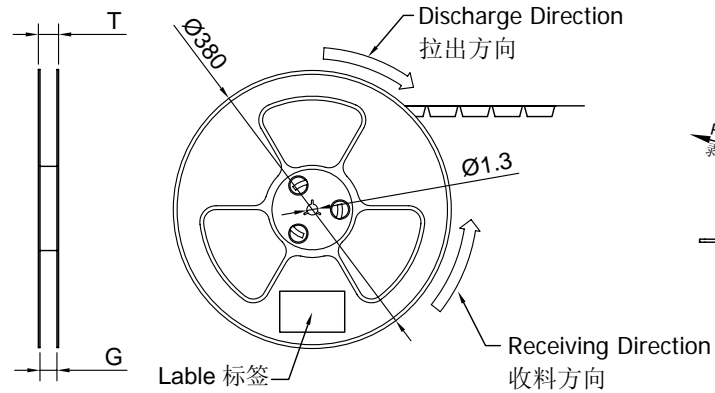
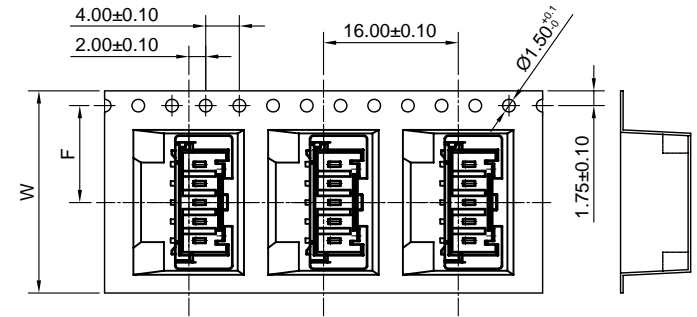
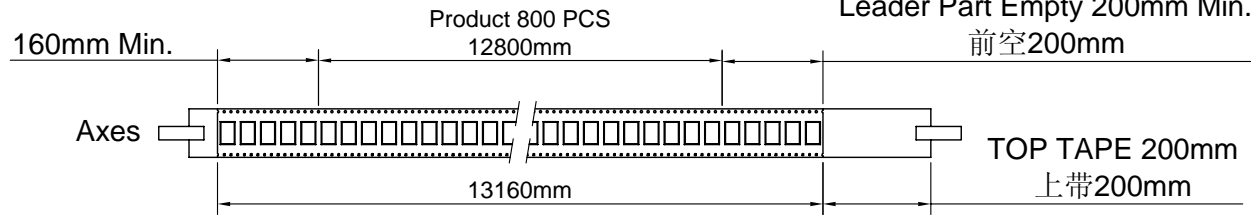

COVER TAPE PEEL STRENGTH: 20~120g
上带剥离力量: 20~120g
速度 PEEL SPEED: 300mm/minute

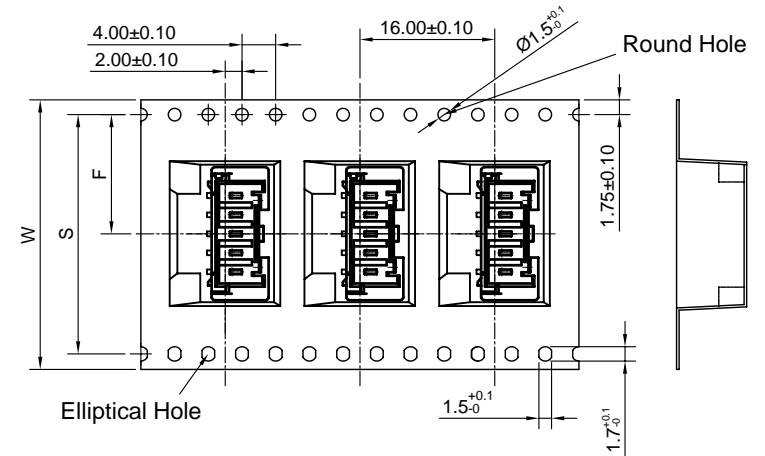
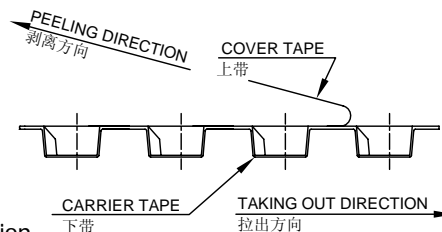

Lable 标签
Single hole: None Hole Side
单孔: 贴无链孔侧
Double hole: Elliptical Hole Side
双孔: 贴椭圆孔侧

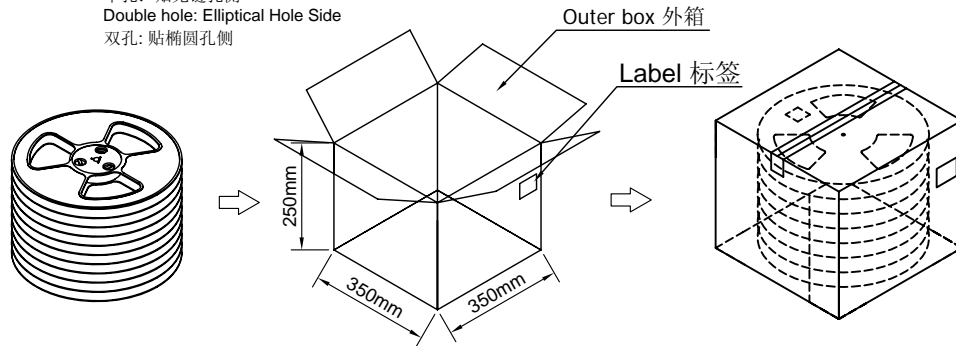

	Pin No.	W	S	F	T	G	REEL /PCS	CARTON /R	CARTON /PCS	
ZD2000WVS-XX 2000WVS-XX-XXXX	ZD2000WVS-02	24	/	11.50	27.0	25.5	800	8	64000	
	ZD2000WVS-03									
	ZD2000WVS-04									
	ZD2000WVS-05	32	28.4	14.20	35.0	33.5	800	6	48000	
	ZD2000WVS-06									
	ZD2000WVS-07									
	ZD2000WVS-08	44	40.4	20.2	47.0	45.5	800	5	40000	
	ZD2000WVS-09									
	ZD2000WVS-10									
	ZD2000WVS-11									
	ZD2000WVS-12									

- Note:**
- Carrier Camber Is Within 1mm In 100mm ; 带长100mm内容许弯曲度1mm
 - 10 Sprocket Hole Pitch Cumulative Tolerance±0.2MM ; 圆孔十个孔距离累计允许公差为±0.2mm
 - Material for PS ; 材质为PS材质
 - Thickness=0.30±0.05 ; 材料厚度为0.30±0.05mm

							GENERAL TOLERANCE		SWB 思索连接器有限公司 SWB CONNECTORS CO.,LTD				PART NO. PPN: 2000WVS-XXX-XXXX CPN: ZD2000WVS-XX			
							.X	±0.30	APPROVAL		CHECK	DRAWN	DATA		TITLE 2.00mm Connectors 180° Package	
DATE	OLD REV	NEW REV	ECN	DESCRIPTION	CHECK	APPROVAL	PROJECT					UNIT	SCALE	NUMBER	REV	
											Allen	MM	1:1	A-106	B	